

World Leader • In-Rack • Audio & Video Monitoring

WOHLER AMP1A

Compact, High Quality Analog Self-Powered Speaker System - 1 Stereo Channel



Features:

- Full Fidelity Audio Monitoring in only 1U of rack space
- 2 Balanced Analog Inputs with Loop-Through (1 Stereo)
- 2 Unbalanced Analog Inputs (1 Stereo)
- Use Either Balanced or Unbalanced Inputs
- Powerful 98dB SPL at 2 feet (0.6m)
- Premium Quality Drivers & Power Amplifiers
- Extended Frequency Response and Low Distortion
- Focused Sound, Reduces Adjacent Bay Crosstalk
- Audible Indication of Phase/Polarity Problems
- Thorough Magnetic Shielding for Placement next to Video Monitors
- Headphone Jack, Mutes Speakers
- Blowout Proof Speakers
- Quick and Simple Installation

The AMP1A provides self-powered, full-fidelity stereo audio monitoring of 2 analog channels (1 stereo channel) in the smallest rack space possible. This unit contains four high performance transducers driven by three power amplifiers: one amplifier/driver combination handles midrange and high frequency information in stereo, while the second handles summed low frequency information below the 500 Hz crossover point.

The unique design provides optimally focused sound for operators in an Ultra Near Field (1 to 3 ft.) working environment and offers performance comparable to that of many separate monitor pairs, yet does so without the installation hassles, awkward speaker placements and "added-on" look. This provides for a higher SPL for the operator while reducing overall ambient sound and adjacent bay crosstalk.

Extended HF response reveals potential problems with audio whine or hiss and electronic rather than acoustic cancellation of bass frequencies provides positive audible detection of out-of-phase (reversed polarity) audio feeds. A headphone jack is provided on the front panel, usage automatically mutes the speakers. Output limiter circuits are incorporated to protect the speakers, and extensive magnetic shielding allows placement immediately adjacent to video monitors with no color impurities.

The AMP1A is ideally suited for use in VTR bays, mobile production vehicles, teleconferencing installations, multimedia systems, satellite link and cable TV facilities, and on-air radio studios. Built and rigorously tested in the USA, the AMP1A is backed by a strong warranty and a "Satisfaction Guaranteed" return policy.



Audio Monitoring

Level Metering

Alarm Systems

Video Monitoring

Toll Free (US): 1-888-5-WOHLER Tel: (650) 589-5676 Fax: (650) 589-1355 • 713 Grandview Drive, South San Francisco, California 94080, USA

www.wohler.com sales@wohler.com

WOHLER AMP1A

Compact, High Quality Analog Self-Powered Speaker System - 1 Stereo Channel

Rear Panel:



System Diagram:

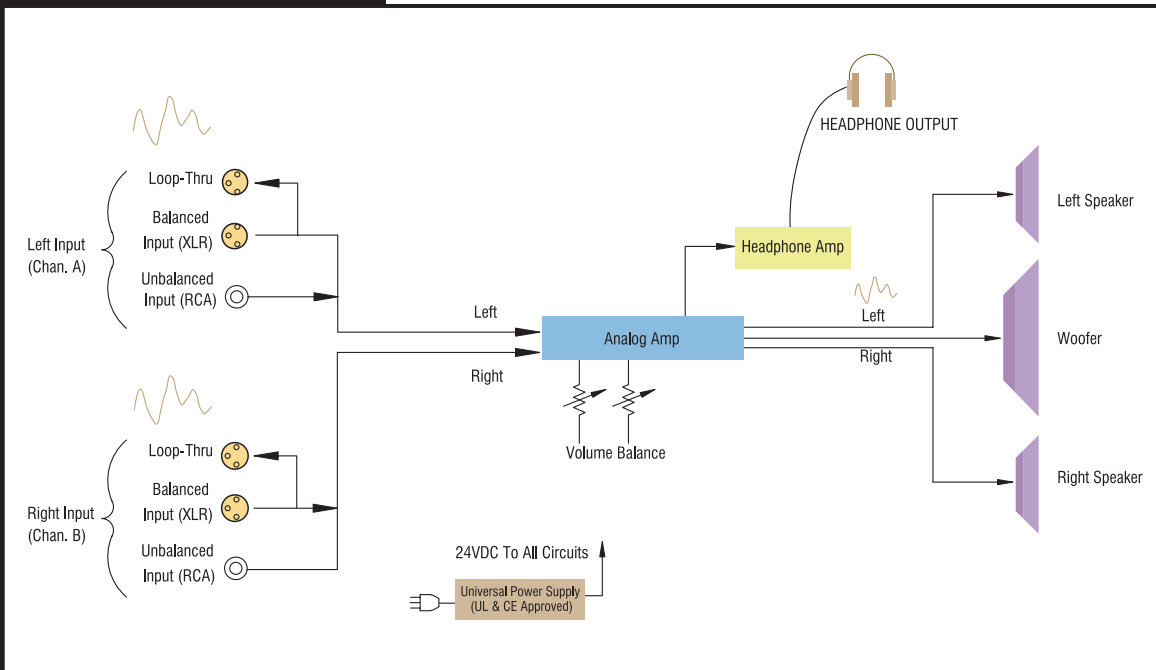

Specifications:

Input	1 stereo balanced or unbalanced analog - XLR / RCA
Output	loop-through of balanced analog input - XLR
Analog input impedance	>40 kOhms balanced 10 kOhms unbalanced
Peak acoustic output @ 2 feet	.98dB SPL
Frequency response (6th octave)	.80Hz - 20kHz (±5dB) (-10dB @ 50Hz, 22kHz)
Power output	RMS each side (2 Ohms) - 5W, 7W peak RMS dual WOOFER (4 Ohms) - 11W, 16W peak
Electrical distortion	<0.15% at any level below input threshold
Hum and noise	better than -68dB below full output
Magnetic shielding	<0.5 gauss any adjacent surface
Power consumption (AVG. MAX.)	.30W
Dimensions (HxWxD)	.175 x 19 x 12" (44.5 x 483 x 305mm)
Weight (approx.)	.12lbs (5.5kg)
Power supply	.100 to 240VAC, 50/60Hz universal input CE and UL approved

All specifications are subject to improvement



Toll Free (US): 1-888-5-WOHLER Tel: (650) 589-5676 Fax: (650) 589-1355
713 Grandview Drive, South San Francisco, California 94080, USA
www.wohler.com • sales@wohler.com