



# PSM<sup>®</sup> 600

## Wireless Personal Stereo Monitor System User Guide



## ! IMPORTANT SAFETY INSTRUCTIONS !

1. READ these instructions.
2. KEEP these instructions.
3. HEED all warnings.
4. FOLLOW all instructions.
5. DO NOT use this apparatus near water. DO NOT expose the apparatus to dripping and splashing. DO NOT put objects filled with liquids, such as vases, on the apparatus.
6. CLEAN ONLY with a dry cloth.
7. DO NOT block any of the ventilation openings. Install in accordance with the manufacturer's instructions.
8. Do not install near any heat sources such as radiators, heat registers, stoves, or other apparatus (including amplifiers) that produce heat.
9. DO NOT defeat the safety purpose of the grounding-type plug. The third prong is provided for your safety. When the provided plug does not fit into your outlet, consult an electrician for replacement of the obsolete outlet.
10. PROTECT the power cord from being walked on or pinched, particularly at plugs, convenience receptacles, and the point of exit from the apparatus.
11. USE only attachments/accessories specified by the manufacturer.
12. USE only with a cart, stand, tripod, bracket, or table specified by the manufacturer or sold with the apparatus. When a cart is used, use caution when moving the cart-apparatus combination to avoid injury from tip-over.
13. UNPLUG this apparatus during lightning storms or when unused for long periods of time.
14. REFER all servicing to qualified service personnel. Servicing is required when the apparatus has been damaged in any way, such as when the power-supply cord or plug has been damaged, liquid has been spilled or objects have fallen into the apparatus, the apparatus has been exposed to rain or moisture, does not operate normally, or has been dropped.



This symbol indicates that there are important operating and maintenance instructions in the literature accompanying this unit.



This symbol indicates that dangerous voltage constituting a risk of electric shock is present within this unit.

**WARNING:** Voltages in this equipment are hazardous to life. No user-serviceable parts inside. Refer all servicing to qualified service personnel. The safety certifications do not apply when the operating voltage is changed from the factory setting.



**WARNING!**

**USE OF THIS SYSTEM AT AN EXCESSIVE VOLUME MAY RESULT IN PERMANENT HEARING DAMAGE. OPERATE AT THE LOWEST POSSIBLE VOLUME.**

In order to use this system safely, avoid prolonged listening at excessive sound pressure levels. Please refer to the following guidelines established by the Occupational Safety Health Administration (OSHA) on maximum time exposure to sound pressure levels before hearing damage occurs.

- 90 dB SPL at 8 hours
- 95 dB SPL at 4 hours
- 100 dB SPL at 2 hours
- 105 dB SPL at 1 hour
- 110 dB SPL at 1/2 hour
- 115 dB SPL at 15 minutes

**120 dB SPL — avoid or damage may occur**

It is difficult to measure the exact Sound Pressure Levels (SPL) present at the eardrum in live applications. In addition to the volume setting on the PSM, the SPL in the ear is affected by ambient sound from floor wedges or other devices. The isolation provided by the fit of quality earpieces is also an important factor in determining the SPL in the ear.

Here are some general tips to follow in the use of this product to protect your ears from damage:

1. Turn up the volume control only far enough to hear properly.
2. Ringing in the ears may indicate excessive gain levels. Try lowering the gain levels.
3. Have your ears checked regularly by an audiologist. If you suffer wax buildup, stop using the system and consult an audiologist.
4. Wipe the ear molds with an antiseptic before and after use to avoid infections. Stop using the ear molds if they are causing great discomfort or infection.

**FCC Statement.** The P6R Receiver complies with part 15 of the FCC Rules. Operation is subject to the following two conditions: (1) This device may not cause harmful interference and (2) this device must accept any interference received, including interference that may cause undesired operation.

**Licensing Statement.** Changes or modifications not expressly approved by Shure Brothers Inc. could void your authority to operate the equipment. Licensing of Shure wireless microphone equipment is the user's responsibility, and licensability depends on the user's classification and application. Shure strongly urges the user to contact the appropriate authority concerning proper licensing.

**Note:** This equipment has been tested and found to comply with the limits for a Class B digital device, pursuant to part 15 of FCC Rules. These limits are designed to provide reasonable protection against harmful interference in a residential installation. This equipment generates, uses and can radiate radio frequency energy and, if not installed and used in accordance with the instructions, may cause harmful interference to radio communications. However, there is no guarantee that interference will not occur in a particular installation. If this equipment does cause harmful interference to radio or television reception, which can be determined by turning the equipment off and on, the user is encouraged to try to correct the interference by one or more of the following measures:

- Reorient or relocate the receiving antenna.
- Increase the separation between the equipment and the receiver.
- Connect the equipment into an outlet on a circuit different from that to which the receiver is connected.
- Consult the dealer or an experienced radio/TV technician for help.

---



---

# TABLE OF CONTENTS

<b>Getting Started with the PSM600</b> .....	<b>3</b>
<b>Introduction</b> .....	<b>4</b>
Description .....	4
Components .....	4
Features .....	4
<b>Overview</b> .....	<b>5</b>
P6T Transmitter .....	5
Front Panel .....	5
Back Panel .....	5
P6R Receiver .....	6
Controls and Connectors .....	6
DIP Switches .....	6
<b>Installation and Applications</b> .....	<b>7</b>
Operating Modes .....	7
Stereo Control .....	7
MixMode Control .....	8
Mono Control .....	8
Loop Applications .....	9
Running Multiple PSM600 Wireless Systems under Stereo Control .....	9
Running Floor Monitors through a P6T Transmitter .....	9
Running Multiple PSM600 Systems under MixMode Control .....	10
Running a Recording Device through a P6T Transmitter .....	10
Accessories .....	11
<b>Troubleshooting</b> .....	<b>12</b>
<b>Appendix A. Specifications</b> .....	<b>12</b>
Custom Earpieces .....	14
Voltage Selection .....	14
<b>Appendix B. Rack Mounting Options</b> .....	<b>15</b>
Rack Mounting the P6T Transmitter .....	15
Front Mounting the Antenna .....	16

# GETTING STARTED WITH THE PSM600 SYSTEM

Thank you for purchasing the PSM600 Personal Stereo Monitor System. The PSM600 is a revolutionary new product family designed to meet the diverse audio monitoring needs of musicians, engineers, and stage performers.

This section outlines step-by-step instructions to quickly show you how to connect your PSM system to an audio source while introducing you to some of its features.

## P6T Transmitter Setup

1. Plug the power cord to the power connector. Connect the other end to a power supply.
2. Attach the antenna to the ANTENNA OUT BNC connector.
3. Plug the cable(s) from the audio source (mixer, audio output, CD player) into the LEFT/RIGHT audio inputs. For a stereo send, use both inputs. For mono send, use either the LEFT or RIGHT input.

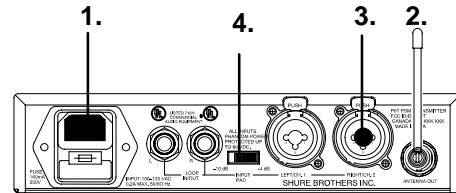

**NOTE:** All inputs are phantom power protected up to 60 VDC.

4. Put the PAD switch in the +4 dB if the input signal is +4 dB, or the -10 dB position, if the input signal is -10 dB.
5. Turn on the P6T Transmitter.
6. Set the SOURCE switch to match the audio send (stereo/mono).
7. Set the FREQUENCY switch in the UP position to frequency #1.

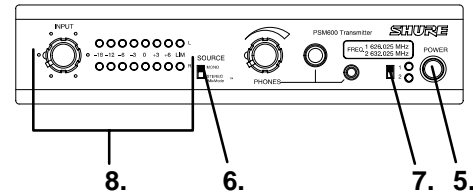

**IMPORTANT:** Never set more than ONE transmitter to the same operating frequency.

8. Power on the audio source and adjust the level control so the LEDs are in the -3 dB to +3 dB range.

## P6R Receiver Setup

9. Attach the bodypack antenna (PA710) to the ANTENNA connector by aligning the red dot and threading the shell until it is tight.
10. Open the battery door and insert a 9V alkaline battery.
11. Set the DIP switches according to the illustration.

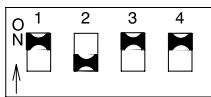

- #1: UP – Frequency #1
- #2: DOWN – Stereo control
- #3: UP – High frequency boost
- #4: UP – Limiter on

12. Set the balance control to the center detent position.
13. Insert the plug of the earpieces into the headphone connector on the top panel.
14. Insert the earpieces into your ears.
15. Turn on the receiver by rotating the volume knob clockwise past the click, then slowly raise the volume to a comfortable listening level.

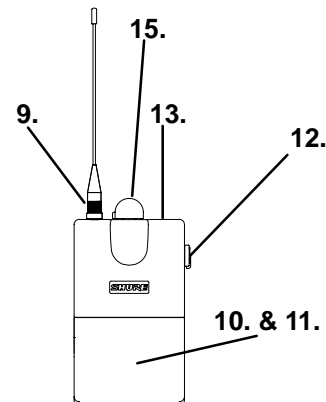

Now you know the basic setup for your new PSM600 Personal Stereo Monitor System. If any troubles occur, please refer to the *Troubleshooting* section of this manual. The rest of the manual goes into greater detail on features and applications — including MixMode™ control, which enables you to customize your own mixes. Please read the rest of the manual to help you make the most of your PSM600 System.

# INTRODUCTION

## Description

The Shure PSM600 Personal Stereo Monitor System is a UHF wireless, two-channel stereo, monitor system designed for onstage applications. The PSM has several advantages over onstage loudspeaker monitors: it is less visible, has better sound, allows freedom of movement, and reduces the chances of feedback. It is a versatile system, designed for use in many different sound reinforcement applications: public address, live music, theater, and electronic news gathering (ENG). The wireless system is frequency compatible with other Shure UHF and VHF wireless systems.

## Components

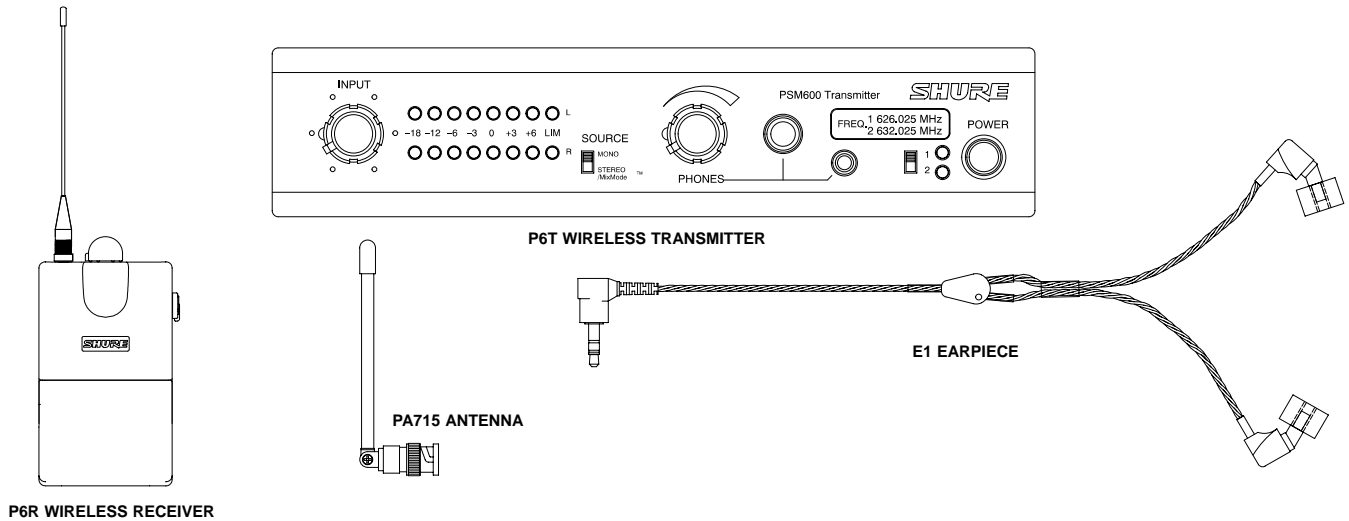

**P6T Wireless Transmitter** with rack-mounting hardware and one antenna  
**P6R Wireless Body-Pack Receiver** with antenna  
**E1 Earpieces** with foam ear inserts

## Features

- UHF operation.
- Stereo or MixMode™ control for custom monitor mixes.
- 2 user-selectable frequencies per system.
- Up to 10 compatible frequencies for 10 separate mixes.
- Frequency compatible with all Shure Wireless systems (country dependent).
- MPX Stereo audio transmission.
- Switchable high-frequency boost on P6R.
- +4 dBu/-10 dBV input level select switch on P6T.
- Electronically balanced, combined 1/4-in./XLR connectors on P6T can be used with balanced or unbalanced connections.
- Volume and Balance dials on the P6R Receiver for easy user access.
- Internal linear power supply on P6T, switchable between 120 VAC and 230 VAC.
- Peak transmitter modulation limiter with fixed threshold and modulation limit indicators.
- Loop out connectors on P6T for multiple mix setups and easy installation.
- Tone-Key squelch.
- Half-rack chassis on P6T complete with mounting hardware.
- All metal construction on P6T and P6R
- Headphone monitor on P6T for local listening.

# OVERVIEW

## P6T Transmitter

### Front Panel

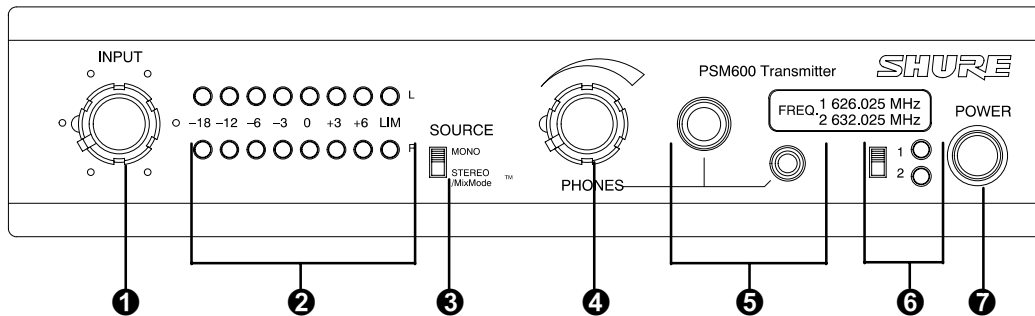

- ❶ **INPUT Dial.** This controls the signal level to the transmitter modulator. For optimum sound, the input level should be set in the  $-3$  dB to  $+3$  dB range.
- ❷ **Stereo INPUT Meters.** Each channel has an eight LED meter which indicates the modulation level of the radio signal. Important: When the LIM (limit) LEDs illuminate, the system is overdriven. Reduce the input knob to keep the input level LEDs at around  $-3$  dB to  $+3$  dB.
- ❸ **SOURCE Switch.** Set to MONO when only one input is needed. Set to STEREO/MixMode when both inputs are needed.
- ❹ **PHONES Volume Dial.** This dial controls the signal level to the headphone output, without affecting the input level.
- ❺ **Headphone Connectors —  $1/4$ -in. phone and 3.5 mm ( $1/8$ -in) mini.** Each connector is configured as left=tip, right=ring, ground=sleeve. Please note that only one of these outputs can be used at a time.
- ❻ **Frequency Switch and Indicators.** This switch determines the frequency the P6T transmits. The frequencies your particular unit operates at are indicated just above this switch. The LEDs indicate which frequency the unit is transmitting: RED = frequency 1, GREEN = frequency 2. These LEDs also act as power-on indicators.
- ❼ **Power Switch.** Press this button to turn the unit on.

### Rear Panel

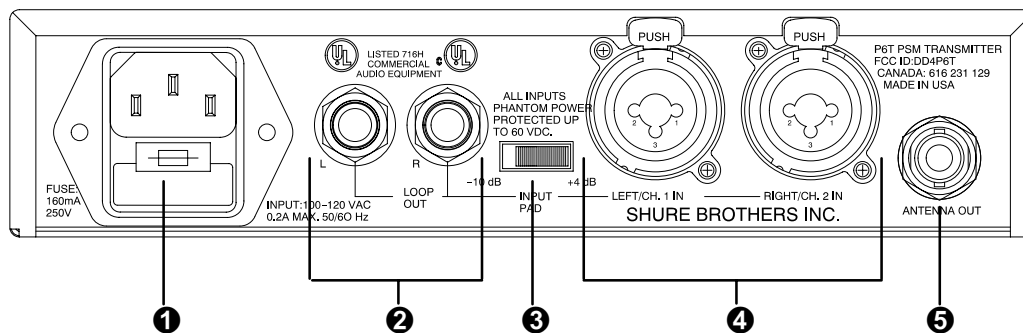

- ❶ **Power Connector with Integral Fuse.** Connects to a power supply. The fuse is located in the bottom drawer.
- ❷ **LOOP OUT Connectors —  $1/4$ -in. phone, balanced.** Additional connectors internally wired to the respective LEFT/RIGHT input connectors.
- ❸ **INPUT PAD Switch.** Selects the input level for  $-10$  dBV or  $+4$  dBu operation.
- ❹ **LEFT/CH. 1 and RIGHT/CH. 2 Input Connectors — Combined  $1/4$ -in. phone and XLR (female), balanced.** Electronically balanced inputs can be used with either balanced or unbalanced outputs. Either connector can be used for mono control.
- ❺ **Antenna Connector —  $50 \Omega$ , BNC type.** This connects to the antenna to transmit UHF signals to the receiver.

# P6R Receiver

## Controls and Connectors

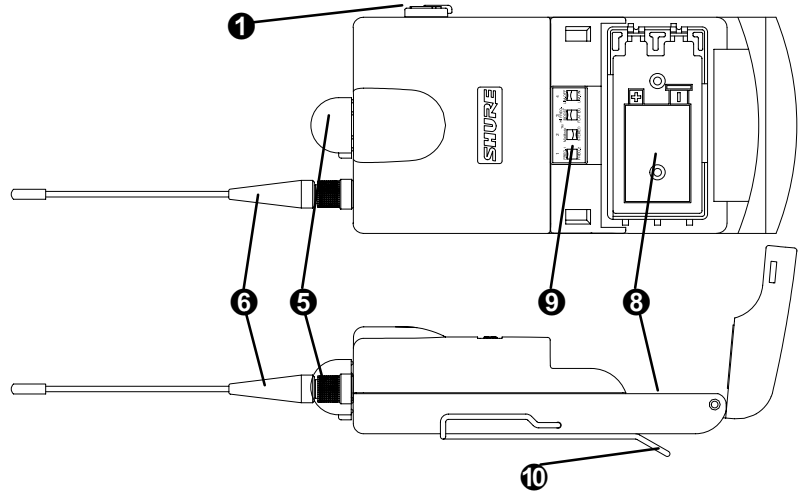
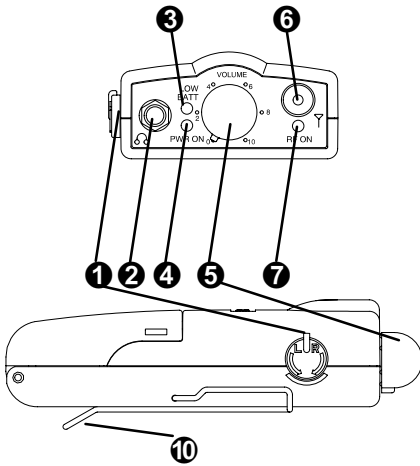

- ❶ **Balance Dial.** In stereo mixes, this controls the left/right balance. In MixMode™, this controls the mix level of two transmitter inputs.
- ❷ **Headphone Connector.** 3.5 mm (1/8-in.) jack connects to the E1 earpieces. Left=tip, right=ring, ground=sleeve.
- ❸ **LOW BATT Indicator.** This red LED illuminates when the battery has approximately 45 minutes of operating time remaining, depending on the volume.
- ❹ **Power LED.** This green LED illuminates when the power is ON and the battery is good.
- ❺ **ON/OFF and Volume Dial.** Full counter-clockwise turns the P6R OFF. Turn the dial clockwise past the click to turn the P6R ON. Once ON, turn the dial

clockwise to raise the volume, and counter-clockwise to lower the volume in the earpieces.

- ❻ **Antenna and Connector.** An easily removable antenna connects to the P6R to receive RF signals from the P6T Transmitter.
- ❼ **RF LED.** Illuminates when the P6R is receiving a signal from the transmitter.
- ❽ **Battery Compartment.** Accepts one 9-volt battery (Duracell recommended). Open the door by pressing the latches on both sides and pulling.
- ❾ **DIP Switches.** Using the DIP Switches, you can customize the operation of the receiver. See *DIP Switches* (below).
- ❿ **Belt Clip.**

## DIP Switches

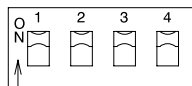

DIP SWITCH	FUNCTION	UP	DOWN
1	Frequency Select	Frequency 1	Frequency 2
2	Stereo/MixMode Select	MixMode control	stereo control
3	Equalization (Flat/High Boost)	Gives a 6 dB boost at 10 kHz for a better high-end response	normal response
4	Limiter defeat	Limiter on	Limiter off

**IMPORTANT:** The Limiter is designed to respond to and limit the loudness of unexpectedly high signals. It is not designed to prevent long term exposure to high SPL levels. *It is designed for use with the E1 earpieces, so the maximum limited SPL may be different with other earpieces.* We recommend that you always use the built-in limiter provided with this system. However, a limiter defeat switch has been provided for those who would prefer to use an external limiter product.

# INSTALLATION AND APPLICATIONS

The flexible design of the PSM600 Personal Stereo Monitor System makes configuring a monitor mix very simple. In addition, the unique MixMode circuitry enables you to customize your own individual mix in a multiple mix environment. To help you install the PSM600 into your sound system, the tables and diagrams in this section describe three distinct modes of operating or controlling the system. Although the examples show only single system setups, you can configure multiple wireless systems in a setup. Some multiple mix setups are detailed in the *LOOP Applications* section of this chapter.

## Operating Modes

<b>Stereo Control</b>	Used for conventional Stereo monitor mixes. <i>Transmitter</i> Stereo/MixMode setting <i>Receiver</i> Stereo setting <i>Balance Dial</i> Varies stereo left/right image
<b>MixMode Control</b>	Used for creating an individual mix between two distinct monitor sends. <i>Transmitter</i> Stereo/MixMode setting <i>Receiver</i> MixMode setting <i>Balance Dial</i> Varies levels between mixes
<b>Mono Control</b>	Used when only one (mono) monitor mix is available. <i>Transmitter</i> Mono setting <i>Receiver</i> Stereo setting <i>Balance Dial</i> Varies the right/left volume control

**NOTE:** For consistency throughout the following diagrams, a mixing console is shown as the source supplying the audio signal to the P6T Transmitter. However, any balanced or unbalanced send that outputs a line level should drive the P6T Transmitter adequately. Some devices that would work are a CD player, DAT machine, direct out box, signal processing equipment, and microphone preamps.

### Stereo Control

This diagram shows how to connect the PSM600 system with a stereo monitor mix.

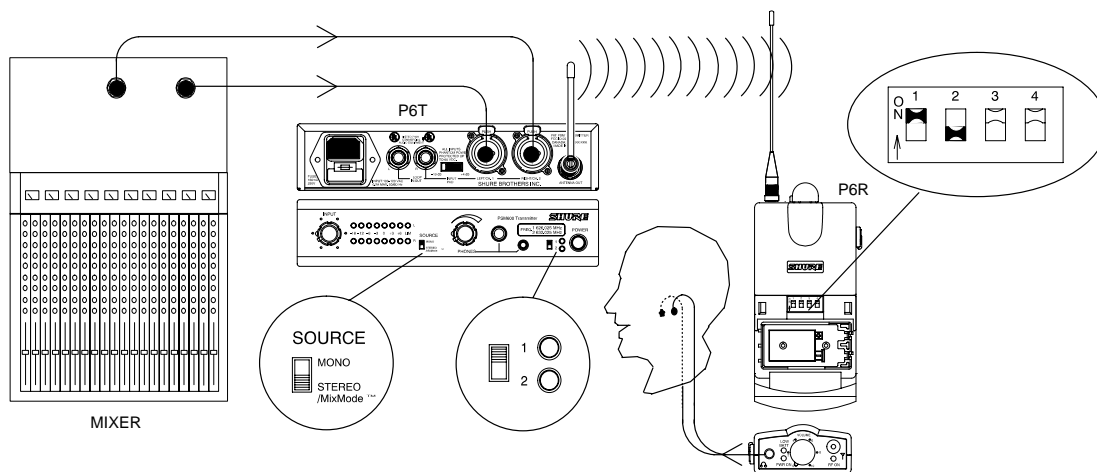

1. Connect the stereo mixer outputs to the L/CH1. and R/CH2. INPUTs on the P6T Transmitter
2. Set the SOURCE switch on the P6T front panel to STEREO.
3. Set DIP switch 2 of the P6R Receiver to STEREO.
4. Set DIP switch 1 on the P6R and the FREQ. switch on the P6T to the same frequency.
5. Use the balance dial on the P6R Receiver to adjust the balance of the Right and Left channel volume.

## MixMode Control

This diagram shows how to connect the PSM600 system with two monitor mixes combined at the receiver. This allows you to vary the level between the two mixes to create a custom mix.

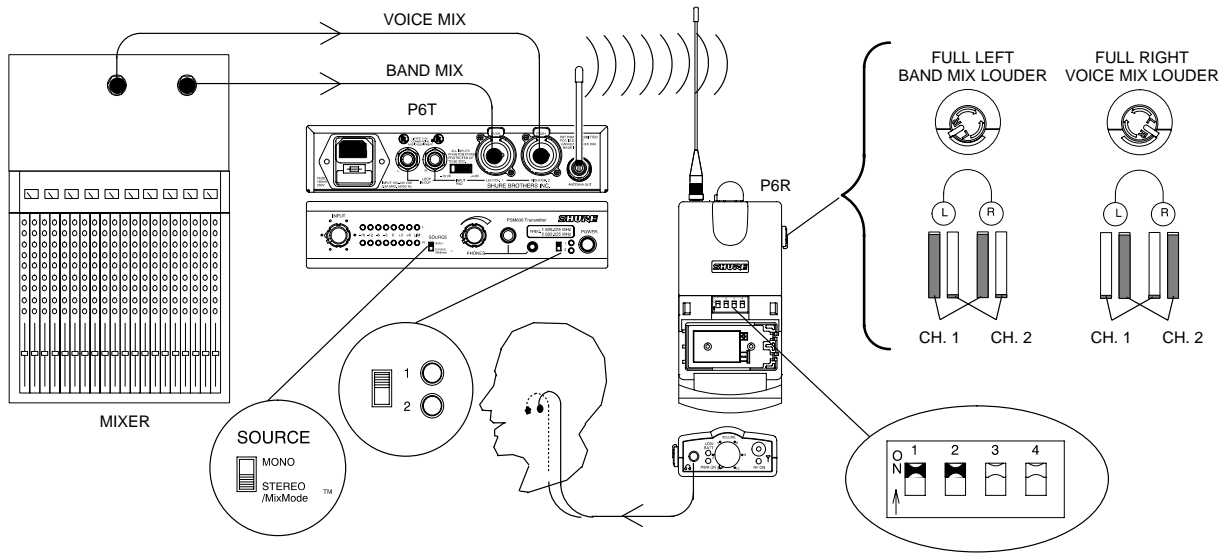

1. Connect the monitor mix 1 and monitor mix 2 mixer outputs of the mixer to the L/CH. 1 and R/CH. 2 audio inputs of the P6T Transmitter.
2. Set the SOURCE switch on the P6T Transmitter to STEREO.
3. Set DIP switch 2 on the P6R Receiver to MixMode™.
4. Set DIP switch 1 on the P6R and the FREQ. switch on the P6T to the same frequency.
5. Use the balance dial on the P6R to adjust the relative levels between the two monitor mixes.

## Mono Control

This diagram shows how to connect the PSM600 system with a mono monitor mix.

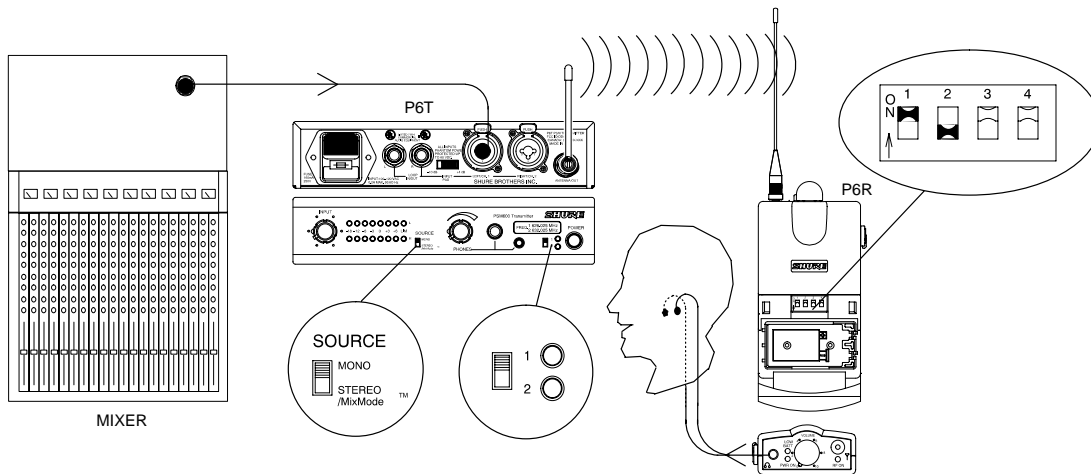

1. Connect the mono monitor output of the mixer to either the Left or Right audio inputs of the P6T.
2. Flip the SOURCE switch on the front panel to MONO.
3. Flip DIP switch 2 of the P6R to STEREO.
4. Set DIP switch 1 on the P6R and the FREQ. switch on the P6T to the same frequency.

## LOOP Applications

The LOOP OUT L (left) and R (right) outputs allow the signal going through the P6T to be run to other devices. The LOOP feature of the P6T can be used for any number of applications. Shown here are only a few examples of how it can be used.

**NOTE:** The LOOP connectors act as either inputs or outputs. They can be used as outputs when the LEFT and RIGHT INPUT connectors are used for input. However, LOOP connectors can also act as inputs when connected directly to the outputs of a mixer. When the LOOP connectors are used as inputs, the LEFT and RIGHT INPUT connectors act as outputs. These diagrams show the LOOP connectors being used as outputs. Also, the input pad does not affect the level of the LOOP signals.

### Running Multiple PSM Wireless Systems Under Stereo Control

The LOOP INPUT connectors can be used to send the same monitor stereo signals to multiple P6T wireless transmitters. This will free up busses on the mixing console, allowing you more freedom with your audio system. Simply connect a P6T to the mixing console as described in *Stereo Control*, then run 1/4-in to 1/4-in from the L/R LOOP connectors of the first unit to the LEFT/RIGHT Input connectors of the next unit. Connect subsequent unit in the same way.

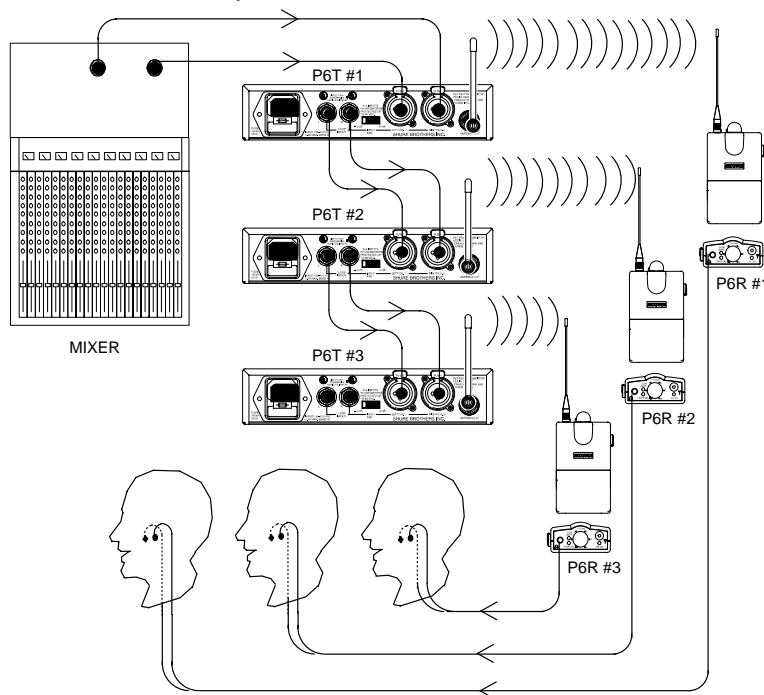

### Running Floor Monitors Through a P6T Transmitter

The monitor audio signal can be sent through the LOOP connectors to another amplifier, such as an amplifier for an onstage monitor system. When setup this way, the P6R and the onstage monitors will have the same audio.

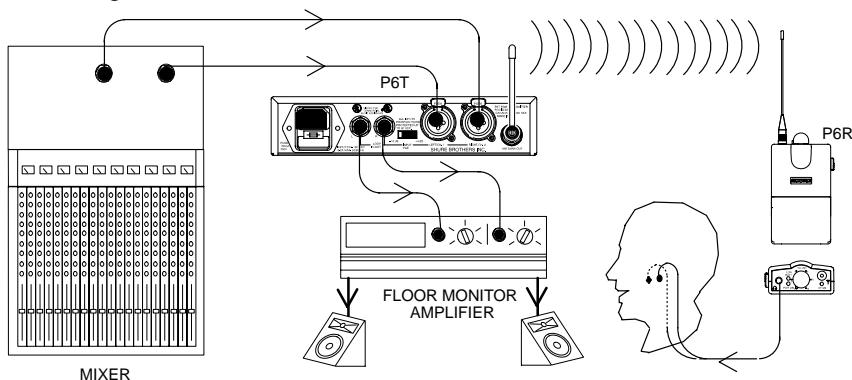

## Running Multiple PSM Wireless Systems Under MixMode Control

A main mono monitor mix can be sent to multiple P6T transmitters, then independent monitor mixes can be sent to the second channel of each. This will allow an entire band to hear the same monitor mix, while giving each individual player a separate mix of their own. Each player can then use the balance knob to adjust the levels between their own mix and the main mono monitor mix.

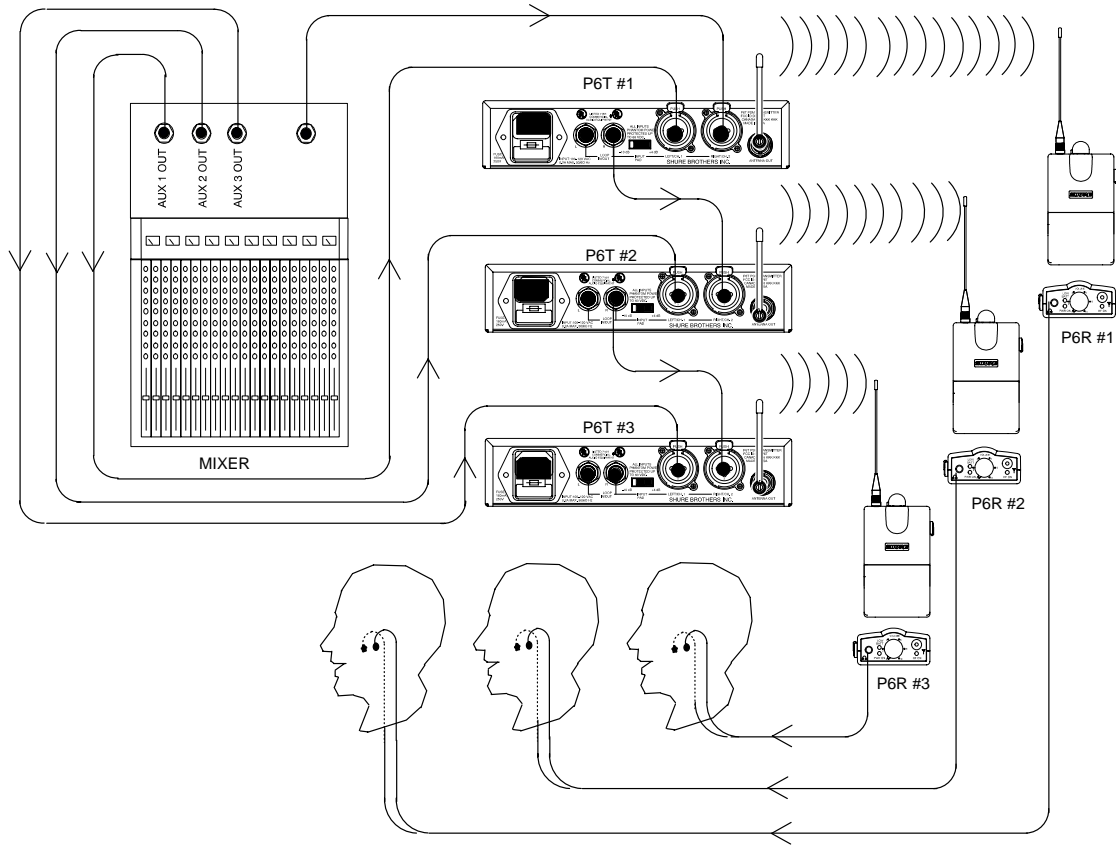

## Running a Recording Device Through a P6T Transmitter

If you would like to make a recording of a performance, the LOOP outputs can be connected to the inputs of a tape deck, DAT, or other recording device.

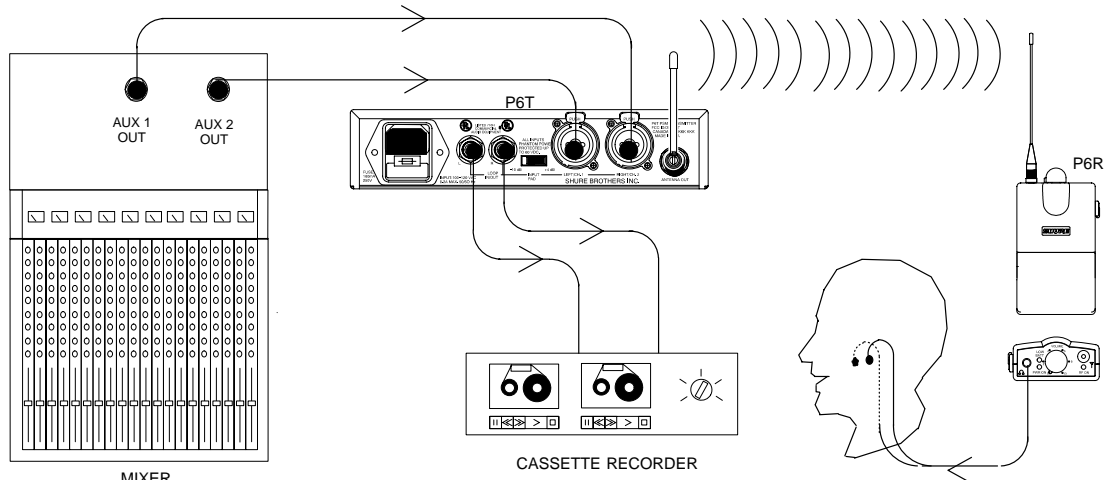

# ACCESSORIES

Several additional products have been developed as part of the PSM product family. These products can enhance the operation of your system, and must be purchased separately.

## PA705 Unidirectional Antenna

The PA705 is a unidirectional, remote-mountable, wideband transmitting antenna designed to provide wireless coverage in a cardioid pattern. You can use the PA705 to secure a line-of-sight transmission path from the transmitter to the receiver when the actual transmitters are obscured. Also, since the PA705 has some gain (due to its directivity), it is also useful when covering very long distances with your wireless system.

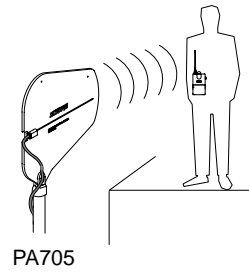

## PA760 Antenna Combiner

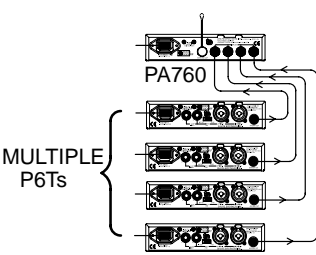

The PA760 is a breakthrough new product specifically designed to improve the performance of multiple wireless monitor systems. First, it combines up to four P6T Transmitters into a single antenna with no signal loss, thus reducing stage clutter without losing wireless range. The PA760 significantly reduces interference by lowering the Intermodulation Distortion (IMD) levels between the four transmitters. The PA760 is an internally-powered, half-rack unit — transportation and setup are easy. Please note that the PA760 cannot be cascaded to other PA760's.

## P6HW Hardwired Body Pack

The P6HW is a hardwired version of the Personal Stereo Monitor for users who do not need the mobility of wireless systems, such as drummers or keyboard players. The P6HW has the same features as the wireless version (Stereo control, MixMode control, limiter, etc.) at a lower price. The P6HW also includes an input pad for increased dynamic range, as well as an input peak indicator to alert the user when levels are too high.

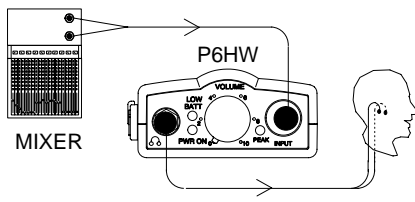

## E1 Earpieces

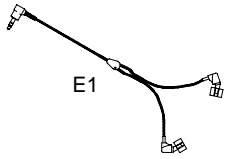

The E1 is an earpiece set designed exclusively for PSM products that can fit anybody. The transducers are optimized for superior sound quality and the earpieces can be customized with special earmolds tailored to fit your ear precisely. For more information, see *Custom Earpieces* under *Appendix A. Technical Specifications*.

# TROUBLESHOOTING

PROBLEM	SOLUTION
No sound at the Receiver	<ul style="list-style-type: none"> <li>✓ Check the power cord on the Transmitter and make sure it is powered on.</li> <li>✓ Make sure both the transmitter and the receiver are set to the same frequency.</li> <li>✓ Make sure the earpiece is plugged into the receiver.</li> <li>✓ Make sure receiver is on and the battery is good.</li> <li>✓ Make sure both antennas are correctly attached.</li> <li>✓ Listen to the headphone monitor on the transmitter to check audio feed.</li> </ul>
Low Receiver Range	<ul style="list-style-type: none"> <li>✓ Make sure all antennas are fully inserted and secured onto jacks.</li> <li>✓ Try to maintain line-of-sight between transmitter and receiver.</li> <li>✓ Try the other frequency in case interference is limiting the range.</li> <li>✓ Check for television channel interference.</li> <li>✓ Make sure the PA715 antenna is not remote mounted.</li> </ul>
Receiver sounds fuzzy or distorted	<ul style="list-style-type: none"> <li>✓ Make sure no other transmitters are operating on your frequency.</li> <li>✓ Make sure transmitter input level is 0 dB <math>\pm</math>3 dB for optimum performance.</li> <li>✓ Listen to the headphone monitor on the transmitter to check audio feed.</li> <li>✓ Try and maintain a minimum of 10 ft. between transmitter antennas and receiver when using multiple transmitters.</li> </ul>
Low audio output at the receiver headphones	<ul style="list-style-type: none"> <li>✓ Make sure transmitter input level is 0 dB <math>\pm</math>3 dB for optimum performance.</li> <li>✓ Switch the transmitter pad to -10 dBV position if the input is too low.</li> </ul>

## APPENDIX A. TECHNICAL SPECIFICATIONS

### SYSTEM

#### RF Carrier Frequency Range

626 to 862 MHz (country dependent)

#### Audio Frequency Response

50 to 15k Hz (+0, -3 dB re 1KHz); earpiece dependent

#### Operating Range

300 ft. (environment dependent)

#### Modulation

FM  $\pm$ 35 kHz Deviation (Nominal), MPX Stereo

#### Channel Separation

35 dB typical

#### Total Harmonic Distortion

0.8% typical (Ref.  $\pm$ 35 KHz deviation)

#### Signal-to-Noise Ratio

80 dB typical (A-weighted)

#### Operating Temperature

-7° C to +49° C (20° F to 120° F)

### Polarity

P6T audio inputs to P6R audio outputs: Non-inverting  
 XLR: pin 2 positive with respect to pin 3  
 1/4-in. TRS: Tip positive with respect to ring

### Certification

**P6T:** Certified to FCC Part 74 (FCC ID No. DD4P6T). Certified in Canada by IC under RSS-123. UL and cUL Listed to UL 813 and CSA C22.2 No. 1.

**EP6T:** Meets essential requirements of European R&TTE Directive 99/5/EC, eligible to carry the CE mark: **CE 0682 0**. Type approved to EN 300 422 Parts 1 and 2. Meets requirements of EMC Standard EN 301 489 Parts 1 and 9. VDE GS Certified to EN 60065.

**P6R:** Approved under the Notification provision of FCC Part 15. Certified by IC in Canada under RSS-123. Meets the essential requirements of European R&TTE Directive 99/5/EC, eligible to carry the CE mark. Meets requirements of EMC standard EN 301 489 Parts 1 and 9.

**IMPORTANT!:**

THIS RADIO EQUIPMENT IS INTENDED FOR USE IN MUSICAL PROFESSIONAL ENTERTAINMENT AND SIMILAR APPLICATIONS.

**NOTE: THIS RADIO APPARATUS MAY BE CAPABLE OF OPERATING ON SOME FREQUENCIES NOT AUTHORIZED IN YOUR REGION. PLEASE CONTACT YOUR NATIONAL AUTHORITY TO OBTAIN INFORMATION ON AUTHORIZED FREQUENCIES FOR WIRELESS MICROPHONE PRODUCTS IN YOUR REGION**

**Licensing:** A ministerial license to operate this equipment may be required in certain areas. Consult your national authority for possible requirements.

**P6T TRANSMITTER**

Shure Transmitter Model P6T may be used in the countries and frequency ranges listed in Table 1 on page i.

**RF Output Power**

100 mW (+20 dBm) typical conducted (country dependent)

**Modulation Limiter**

Internal peak limiter (>10:1 compression)

**Antenna**

External whip, 50 Ω BNC connector

**Power Requirements**

P6T: 100 to 120 Vac, 50/60 Hz  
EP6T: 220 to 240 Vac, 50/60 Hz

**NOTE:** This product is not disconnected from the mains power supply when the power switch is in the OFF position.

**Current**

115 mAac maximum at 120 Vac  
55 mAac maximum at 230 Vac

**Fuse**

P6T: 120 Vac, 160 mA/250 V time delay  
EP6T: 230 Vac, 80 mA/250 V time delay

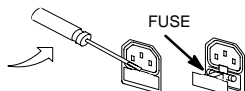

**Dimensions**

44.5 mm X 197.4 mm X 238.1 mm (1 3/4 in. X 7 3/4 in. X 9 3/8 in.)

**Net Weight**

1.62 kg (3 lbs., 9 oz.)

**P6R RECEIVER**

**RF Sensitivity**

1.2 μV typical

**Image Rejection**

70 dB typical

**Spurious Rejection**

60 dB typical

**Squelch Threshold**

4 μV typical

**Antenna Input Impedance**

50 Ω typical

**Antenna**

External, threaded connector

**Power Requirements**

9 V battery

**Battery Life**

4–6 hours, volume dependent

**Audio Output Connector**

3.5 mm Stereo (Left = tip, Right = ring, Ground = sleeve)

**Minimum Load Impedance**

16 Ω

**Net Weight**

0.52 lbs.

**Overall Dimensions**

27.18 mm X 64.52 mm X 85.09 mm  
(1.070 in. X 2.540 in. X 3.350 in.)

**CONNECTORS**

**P6T Audio Inputs (LEFT/CH.1 and RIGHT/CH.2)**

<b>Connector:</b> (XLR and 1/4-inch combined)	XLR (female)	1/4-inch phone jack (female)
<b>Configuration:</b>	electronically balanced	electronically balanced
<b>Actual Impedance:</b>	20 kΩ	20 kΩ
<b>Nominal Input Level:</b>	+4 dBu (+4 input level) -10 dBV (-10 input level)	+4 dBu (+4 input level) -10 dBV (-10 input level)
<b>Maximum Input Level:</b>	+25 dBu (+4 input level) +13 dBu (-10 input level)	+25 dBu (+4 input level) +13 dBu (-10 input level)
<b>Pin Assignments:</b>	Pin 1 = ground Pin 2 = hot Pin 3 = cold	Tip = hot ring = cold sleeve = ground
<b>Phantom Power Protection?</b>	Yes Up to 60 VDC	Yes Up to 60 VDC

**P6T L/R LOOP Outputs (IN and OUT)**

<b>Connector:</b> (XLR and 1/4-inch combined)	1/4-inch jack (female)
<b>Configuration:</b>	electronically balanced
<b>Actual Impedance:</b>	20 kΩ
<b>Nominal Input Level:</b>	+4 dBu (+4 input level) -10 dBV (-10 input level)
<b>Maximum Input Level:</b>	+25 dBu (+4 input level) +13 dBu (-10 input level)

<b>Pin Assignments:</b>	Tip = hot ring = cold sleeve = ground
<b>Phantom Power Protection?</b>	Yes Up to 60 VDC

**FURNISHED ACCESSORIES**

- Body-Pack Antenna ..... PA710
- Transmitter Antenna ..... PA715
- Rack Mount Kit ..... PA745
- Bag of 10 Foam Ear Inserts ..... PA750
- 60 cm (2 ft) Coaxial Cable (RG-58/U) ..... UA802

**OPTIONAL ACCESSORIES**

- Antenna Combiner ..... PA760 (120 VAC)  
PA760E (240 VAC)
- Unidirectional Antenna ..... PA705
- 10 ft Coaxial Antenna Cable (BNC connector) ... PA725
- Triple-Flange Ear Inserts (2) ..... PA755

**CUSTOM EARPIECES**

For information regarding a complete line of custom made musicians' earpieces, contact:

**Ultimate Ears Inc.**

2657 Windmill Pkwy. #391  
Henderson, NV 89014  
(702) 263-7805  
(702) 896-8856 (fax)  
www.ultimateears.com

**Firehouse Productions, Inc.**

12 Boice Road  
Hyde Park, NY 12538  
(914) 229-2055  
(914) 229-0844 (fax)

**Sensaphonics**

660 N. Milwaukee  
Chicago, IL 60622  
(312) 660-1714  
(312) 432-1783 (fax)

**Voltage Selection**

The P6T Transmitter can be internally modified to operate from 230 Vac, 50/60 Hz power.

**WARNING**

Voltages in this equipment are hazardous to life. No user-serviceable parts inside. Refer all servicing to qualified service personnel. The safety certifications of the P6T do not apply when the operating voltage is changed from the factory setting.

To change the operating voltage, follow these steps.

1. Disconnect the P6T from the ac power source.
2. Remove the eight Phillips head screws securing the top cover.
3. Locate Voltage Selector switch SW4 adjacent to power transformer T1 and, using a screwdriver, turn the center rotor to the 230 V position.
4. Locate fuse and remove it. Replace it with a 80 mA, 250 V, time delay fuse for 230-volt operation (160 mA, 250 V, time delay fuse for 115-volt operation).

Fuse part numbers are:

Fuse Type	Shure Part No.	Part No.
80 mA, 250 V time delay	80H380	Schurter .034.3106
160 mA, 250 V time delay	80K258	Littelfuse 218.160

5. Replace the power cord with a cord rated for for 230 V operation, i.e., an IEC appliance connector on the equipment end and a CEE 7/7 ("Schuko") mains connector on the other.\* (Shure part #95A8247.)

Similarly, the EP6T can be internally modified to operate from 115 Vac, 50/60 Hz power.

To change the operating voltage, follow these steps.

1. Disconnect the EP6T from the ac power source.
2. Remove the eight Phillips head screws securing the top cover.
3. Locate Voltage Selector switch SW4 adjacent to power transformer T1 and, using a screwdriver, turn the center rotor to the 115 V position.
4. Locate fuse and remove it. Replace it with a 160 mA, 250 V, time delay fuse for 115-volt operation (80 mA, 250 V, time delay fuse for 230-volt operation).

Fuse part numbers are:

Fuse Type	Shure Part No.	Part No.
160 mA, 250 V time delay	80K258	Littelfuse 218.160
80 mA, 250 V time delay	80H380	Schurter .034.3106

5. Replace the power cord with a cord rated for for 115 V operation, i.e., an IEC appliance connector on the equipment end and a mains connector suitable for 115 V operation on the other.\* (Shure part #95A8389.)

\*For systems requiring other mains connectors, obtain a power cord with an IEC 320 type mating connector for connection to the P6T, and an appropriate plug on the other end for connection to the mains. The supplied cord uses Harmonized IEC Cordage with color coding as follows: Brown = Line, Blue = Neutral, Green/Yellow = Ground.

# APPENDIX B. RACK MOUNTING OPTIONS

## Rack Mounting the P6T Transmitter

**NOTE: Dual mounting with other Shure products.** The P6T can also be dual mounted with a Shure SC or LX half-rack wireless receiver. These same instructions apply, but the front panels will not align evenly. The SC and LX receivers must use the SC and LX rack ears. They cannot be mounted with P6T rack ears. However, the link bars are universal and can be used to connect the P6T with an LX or SC receiver.

**WARNING:** Do not torque the screws too tightly, or the chassis may be damaged.

### Single Unit

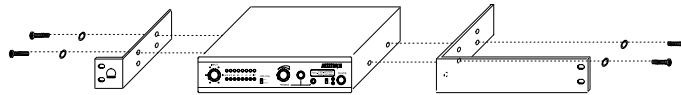

1. Remove the screws and washers from each side of the unit.
2. Align the supplied rackmount brackets over the holes.
3. Using the screws and washers from step 1, fasten the rack-mount brackets.

### Dual-Mounted Units

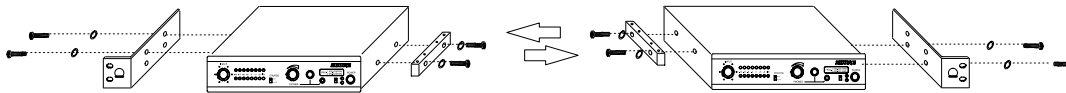

1. Remove the screws and washers on each side of both units.
2. Placing the two units side-by-side, screw the link bars to the inside panels of each unit. The units are designed so that the link bar on the right unit will fit directly on top of the link bar of the left unit (facing front). Use two of the screws and washers from step 1 per link bar to fasten the link bars.
3. Align the rackmount brackets on the outside panels of the units and fasten using four of the screws and washers from step 1.

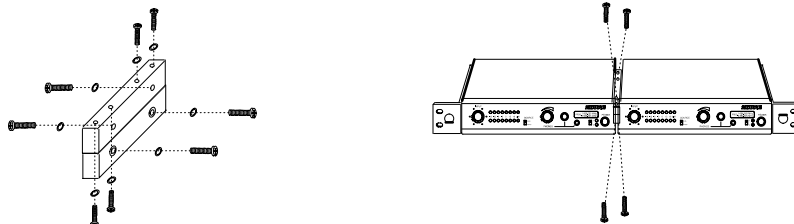

**NOTE:** The link bars are designed with recesses in the side holes where the screw head and washer fit in. Once the link bars are screwed on properly, the vertical holes will align. Each link bar has two threaded holes and two unthreaded holes. In order to ensure proper fit, stack the link bars so that the unthreaded holes on one bar align with the threaded holes on the other bar. Then, each pair of screws fits in the opposite direction of the link, ensuring the stability of the link.

4. Place the two units next to each other so the link bars overlap and the screw holes on the two align.
5. Fasten the link bars together using 4 supplied screws and washers.

### Mounting in an Equipment Rack

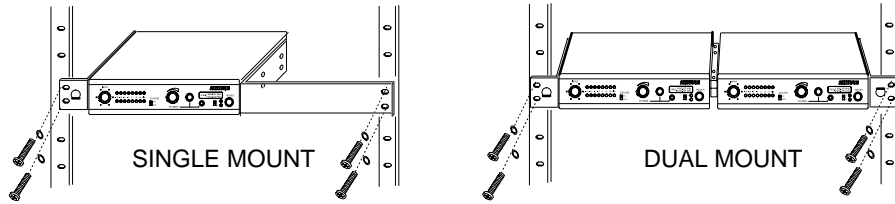

1. Insert the unit(s) into a 19-inch equipment rack.
2. Fasten the unit(s) to the rack using all four of the supplied screws.

## Front Mounting the Antenna

The P6T transmitter comes equipped so the antenna can be front-mounted. Front-mounting prevents antenna cables from becoming entangled and greatly minimizes RF interference from other cables. When a unit is located in a rack, antennas should be either front- or remote-mounted.

1. Insert the bulkhead adapter through the hole of either mounting bracket, and secure it from the front and the back using the supplied hardware.
2. Connect the supplied antenna cables to the transmitter antenna input and bulkhead adapter.
3. Install the antenna on the bulkhead adapter.

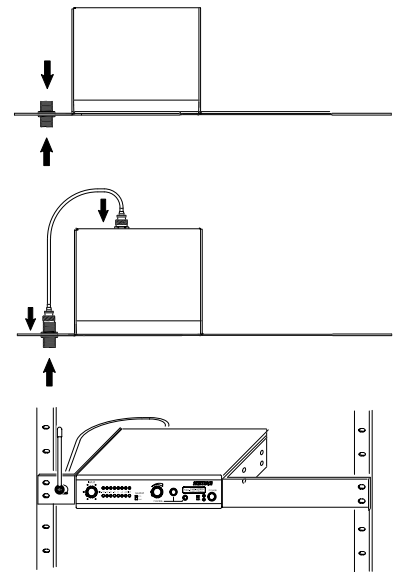

**NOTE:** The PA715 antenna, which comes supplied with the P6T; cannot be remote mounted.

TABLE 1 TABLEAU 1 TABELLE 1 TABLA 1 TABELLA 1

Country Code Code de Pays Länder-Kürzel Código de país Codice del Paese	PT4-HF 800– 830 MHZ *	PT4-MN 854 – 862 MHZ *
A	800 – 830 MHZ *	854 – 862 MHZ *
B	800 – 830 MHZ *	854 – 862 MHZ *
CH	800 – 830 MHZ *	854 – 862 MHZ *
D	800 – 830 MHZ *	854 – 862 MHZ *
E	800 – 830 MHZ *	854 – 862 MHZ *
F	800 – 830 MHZ *	*
GB	*	854 – 862 MHZ*
GR	800 – 830 MHZ *	854 – 862 MHZ *
I	*	*
IRL	800 – 830 MHZ *	854 – 862 MHZ *
L	800 – 830 MHZ *	854 – 862 MHZ *
NL	800 – 830 MHZ *	854 – 862 MHZ *
P	800 – 830 MHZ *	854 – 862 MHZ *
DK	800 – 820 MHZ *	*
FIN	800,1 – 819,9 MHZ *	*
N	800 – 820 MHZ *	*
S	800 – 814 MHZ *	*
All Other Countries Tous les autres pays Alle anderen Länder Demás países Tutti gli altri Paesi	*	*

\*Please contact your national authority for information on available legal frequencies for your area and legal use of the equipment

\*Se mettre en rapport avec les autorités compétentes pour obtenir les informations sur les fréquences autorisées disponibles localement et sur l'utilisation autorisée du matériel.

\*Für Informationen bezüglich der für Ihr Gebiet verfügbaren gesetzlich zugelassenen Frequenzen und der gesetzlichen Bestimmungen für den Einsatz der Geräte setzen Sie sich bitte mit der zuständigen örtlichen Behörde in Verbindung.

\* Comuníquese con la autoridad nacional para obtener información en cuanto a las frecuencias legales disponibles y usos legales del equipo en su área.

\*Rivolgersi alle autorità competenti per ottenere informazioni relative alle frequenze autorizzate nella propria regione e alle norme che regolano l'uso di questo apparecchio.



**SHURE Incorporated** Web Address: <http://www.shure.com>  
222 Hartrey Avenue, Evanston, IL 60202-3696, U.S.A.  
Phone: 847-866-2200 Fax: 847-866-2279  
In Europe, Phone: 49-7131-72140 Fax: 49-7131-721414  
In Asia, Phone: 852-2893-4290 Fax: 852-2893-4055  
Elsewhere, Phone: 847-866-2200 Fax: 847-866-2585