

ALP700A

LPDA Antenna

TECHNICAL DATA



Feature Highlights

- SWR below 2.5:1 from 500 to 800 MHz
- 50 Ohm BNC connector
- 3/8" x 16 threaded stainless steel mounting stud included
- Rods easily replaceable
- Repair kit available
- Optional mounting adapter kit

The ALP700A antenna is an LPDA (Log Periodic Dipole Array) design that provides a useful directional pattern over a broad frequency bandwidth. Most "gain antennas" (those designs with a directional pattern) are limited in bandwidth. This makes them awkward for use in multi-channel wireless systems and with frequency agile wireless systems.

The broad bandwidth of the ALP700A covers the entire UHF band used for Lectrosonics wireless microphone and IFB systems, yet still provides the directional pattern needed to cover long distances.

The antenna is constructed of machined aluminum finished in electrostatic powder coat for lasting ruggedness. Elements (rods) are user replaceable with simple tools.

The antenna is supplied with a stainless mounting stud that adapts it to an optional adapter kit. The adapter kit provides a variety of mounting options.

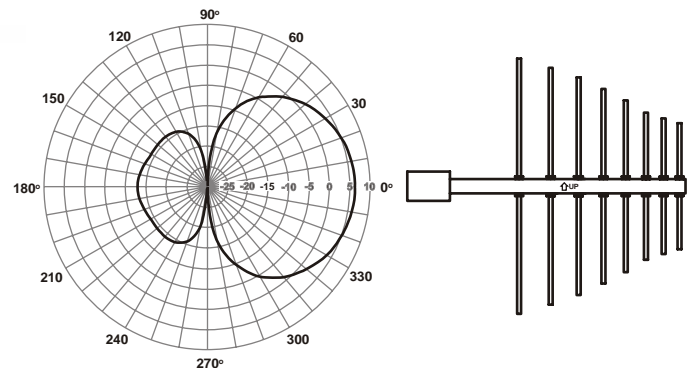

Typical Vertical Pattern

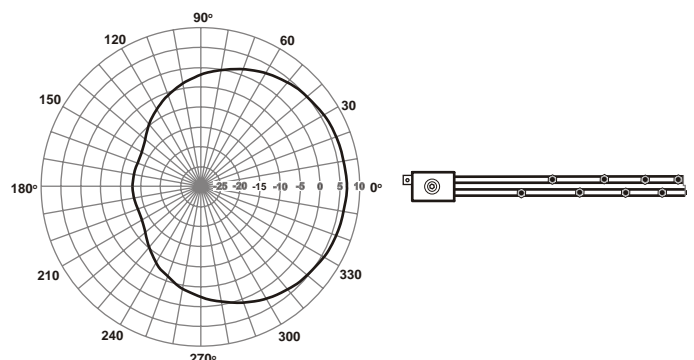

Typical Horizontal Pattern

Orientation and Usage

The smaller rod elements of the antenna should be pointed toward the matching transmitter for maximum sensitivity (note the pattern plots on the first page).

Since a wireless transmitter antenna is generally oriented vertically, the rod elements on the ALP700A should also be oriented vertically. Note the "up" arrow engraved on the boom of the antenna.

The optional mounting adapters permit a wide variety of orientations. It is important to locate the antenna at least a foot or two (or more) away from nearby surfaces. Reflections from nearby surfaces can alter the pattern and/or affect the sensitivity of the antenna to certain frequencies in particular locations.

The coaxial cable connected to the antenna should be routed away from the antenna.



The antenna is terminated with a 50 Ohm BNC connector. The BNC jack is connected to a coaxial line inside the boom opposite the jack.

A 3/8" - 16 threaded mounting stud is supplied to fit the adapters in the optional mounting adapter kit. Two different threaded sockets are available, positioned at 90 degrees from one another to allow horizontal or vertical mounting.

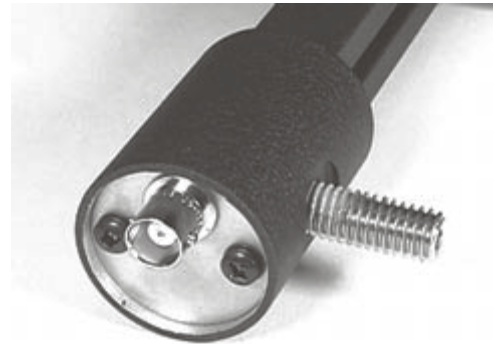

Optional Mounting Adapter Kit

Threaded adapter for standard lighting clamps. 1/2" diameter x 6 inch long. 3/8"-16 thread on both ends.

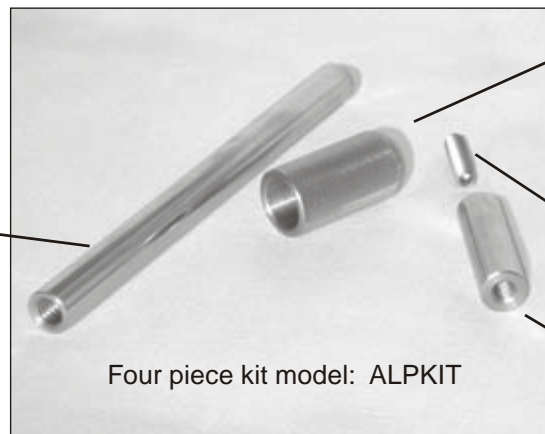

Microphone stand adapter, 1 1/2" long. 5/8"- 27 thread on one end, with 3/8"-16 thread in other end. Knurled finish.

1/4" - 20 threaded adapter.

Threaded adapter for photo/video tripod mounting. 1/2" diameter x 1 3/4" long. 3/8"-16 thread on one end, 1/4"-20 on the other end.

The mounting adapter kit allows mounting on photo and video tripods, lighting equipment, and standard microphone stands. The parts are constructed of stainless steel for lasting durability.

Replacement of Elements

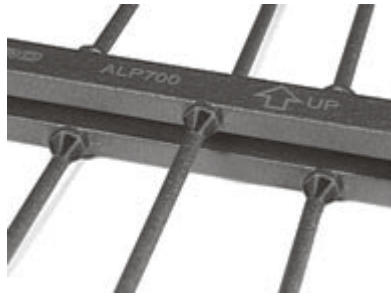

The rod elements of the antenna are secured to the booms with hex nuts. To replace an element, unscrew the nut and remove the threaded end of the rod.

The repair kit includes a full length rod, hex nut and plastic cap. Remove the nut and plastic cap for measurement and cutting.

The length of each element is critical to ensure maximum performance of the antenna. Measure the overall length accurately and cut off the non-threaded end of the rod to the exact length shown in the table below.

Overall Length to Cut Rods

Rod #1 (shortest)	2.840"
Rod #2	3.066"
Rod #3	3.335"
Rod #4	3.915"
Rod #5	4.450"
Rod #6	4.990"
Rod #7	5.440"
Rod #8 (longest)	5.875"

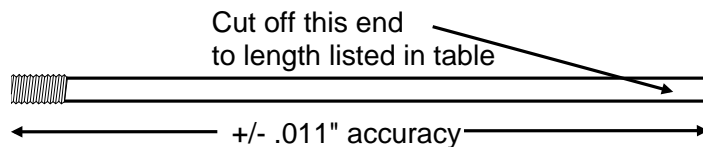

Attach hex nut after rod is cut to length

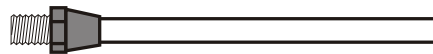

Cross Section/End View

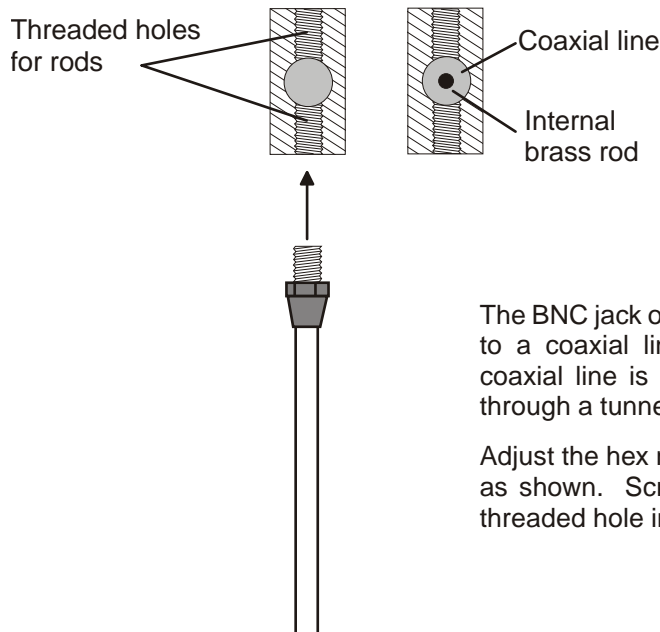

The BNC jack on the end of the antenna connects to a coaxial line inside one of the rails. The coaxial line is formed by a brass rod that runs through a tunnel in the center of the rail.

Adjust the hex nut close to the end of the threads as shown. Screw the replacement rod into the threaded hole in the rail.

Adjustment of Element Length

Accurately measure the length from the edge of the boom (not the hex nut) to the end of the metal rod. Adjust the rod to the exact length shown in this drawing.

When the exact length has been set, hold the rod in place and tighten the hex nut to secure the rod. Measure the length again to ensure accuracy.

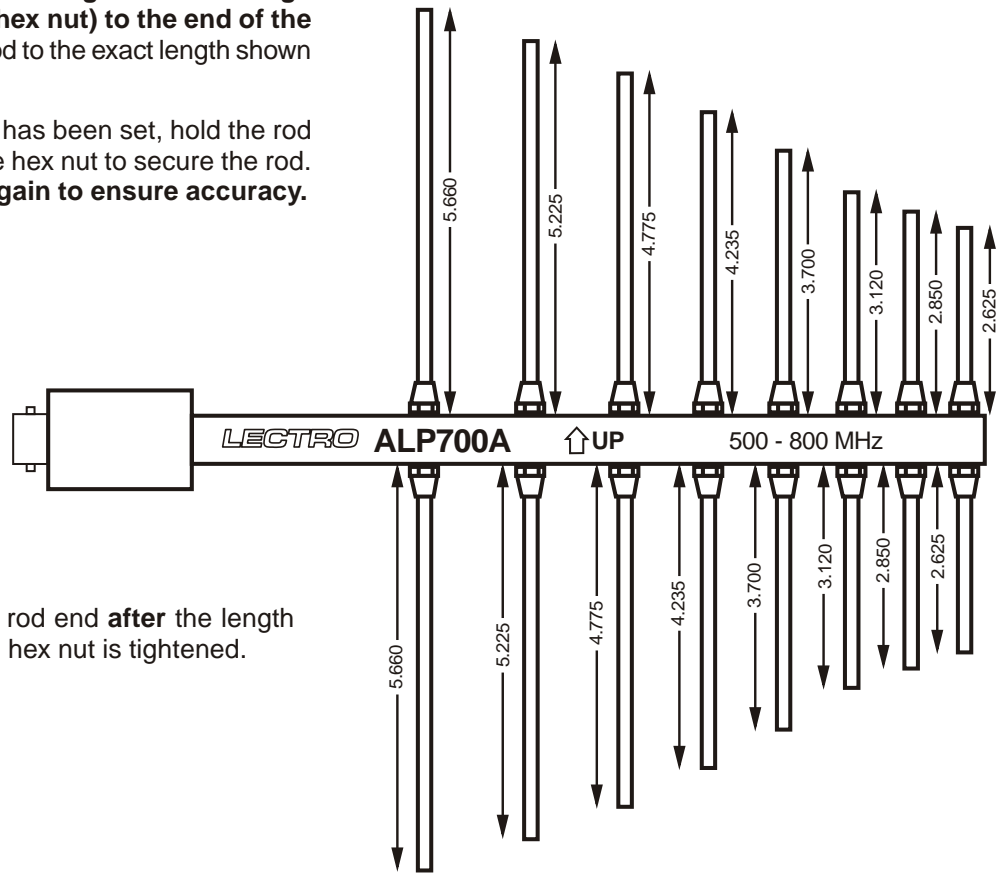

Install plastic cap onto rod end **after** the length has been adjusted and hex nut is tightened.

Specifications

Gain:	+7dBi (isotropic) +4dBi over dipole
Range:	500-800 MHz
Weight:	15.6 ozs
Connector:	50 ohm BNC
Dimensions:	13.5" long x 12.25" wide

ALP700TD-06/00



LECTROSONICS,