

MS-200
Two-Channel
Main Station
INSTRUCTION
and
SERVICE MANUAL



1111 17th Street • San Francisco, California 94107 • 415-861-6666

THE CLEAR-COM MS-200 MAIN STATION OPERATION MANUAL

I	INTRODUCTION	
	A The Clear-Com Concept.....	1
	B The MS-200 Two Channel Main Station.....	2
II	INSTALLATION	
	A. Maximum Amount of Stations.....	3
	B. Cable Considerations.....	4
	Portable and Permanent Installation	
	Multi-Channel Considerations	
	C. Installation Considerations.....	6
	Multiple Power Sources	
	Complete Loop-Through Set-Up	
	Signalling Configurations	
	In-Line Isolation	
	Interfacing with Other Systems	
	D. Interconnection Set-Up.....	8
	E. Headsets and Mics.....	10
	F. Typical MS-200 Intercom Systems.....	11
III	OPERATION OF THE MAIN STATION	
	A. Set-Up Procedures.....	15
	Termination	
	Headsets, Speaker, & Gooseneck Mic	
	Program Input	
	Preselection of Channel Activity	
	Monitor Select Buttons	
	Call & All Page	
	Variable Controls	
	B. Operation Checklist.....	18
	C. Warranty and Maintenance.....	19
IV	TROUBLE-SHOOTING	21
V	SPECIFICATIONS	23
VI	PARTS LISTING	25
VII	INTERFACES & OPTIONS	27
	Interfacing with: External Audio	
	Adapt-A-Com	
	TELCO Line	
	Wireless System or 4-Wire	
	Visual Signalling Modification	
	Main Station/Power Supply Interconnection	
	Conversion to 220 VAC	
VIII	THEORY OF MS-200 OPERATION	31
	Figure 1 Maximum Amount of Remote Stations.....	3
	Figure 2 Belden Shielded Cables.....	5
	Figure 3 Clear-Com Model BA-1 In-Line Isolator.....	7
	Figure 4 Two-Channel Fixed Installation Wiring.....	9
	Figure 5 MS-200 Front Panel.....	14
	Sect. IIF Typical MS-200 Intercom Systems.....	12-13
	Sect. VII Interface and Option Diagrams.....	27-28
	Sect. VIII Schematic Diagrams.....	33-35

I. INTRODUCTION

A. The Clear-Com Concept

Clear-Com is a closed-circuit intercom system that consistently provides crystal-clear, two-way communications in high- and low-noise environments. A basic system consists of a single or multi-channel Power Supply or Main Station connected to various single or two-channel Remote Stations.

Clear-Com offers a wide variety of both portable and fixed-installation units. All are compatible with each other; Clear-Com also interfaces with other communications products (see Sections IID and VII).

A Clear-Com System is most often connected with standard, two-conductor shielded mic cable, using D3M audio connectors. One wire carries the DC power (28-32 volts) from the Main Station or Power Supply to all Remote Stations, and the other wire carries the audio signal. The shield acts as a common ground. Only one termination is needed in the System, and is accomplished at the Main Station or Power Supply.

Clear-Com is a distributed amplifier system; each Main and Remote Station houses its own mic preamplifier, power amplifier (for the headset or speaker), and signal circuitry. Each unit also contains Automatic Headset Detection, which shuts off a station's mic preamp when its mic or headset is disconnected; hence, background noise on the line is not increased by an unused yet on-line station.

Clear-Com Main Stations, Power Supplies, and certain Remote Stations each have an auxiliary input with its own volume control, which allows the operator to monitor an external program. Visual Signal circuitry, a standard feature on most Main and Remote Stations, allows the user to attract the attention of operators who have removed their headsets.

Depending upon the type of units in a system, a maximum number of Remote Stations from 20 (speaker) to 100 (headset) can be distributed along a mile of wire. Remote Stations bridge the intercom line at a very high impedance and place a minimum load on the line. Audio level remains constant, never fluctuating when stations leave or join the line. Low-impedance mic input lines and specially designed circuitry result in a system virtually immune to RF and dimmer noise.

The DC voltage provided by the Main Station or Power Supply enables Remote Stations to operate with minimal current (10 milliamperes quiescent for headset stations, 20 ma quiescent for speaker stations) while generating extremely loud listen levels (greater than 110 dB SPL). The higher voltage and low current keep voltage losses to an absolute minimum in long lines. If the voltage drops due to the addition of great lengths of cable or many more stations, Clear-Com will continue normal operation with less than 12 volts available.

B. THE MS-200 TWO-CHANNEL MAIN STATION

The MS-200 is a two-channel master intercom station with a regulated power supply and a pre-settable monitoring system. Its integral mic preamplifier with limiter and four-watt power amplifier provide sufficient power to simultaneously drive two headsets and an internal or external speaker.

The MS-200 will support two channels fed to as many as 100 headset stations, or 20 speaker stations, or 20 RM-400 Dual-Channel Remote Stations (the allowable maximum amount of mixed stations is discussed in a later section). The operator enables each channel with separate, locking pushbuttons which light dimly when "on." This arrangement allows the operator to monitor each channel separately or simultaneously; the choice to monitor both at once does not involve communication between the two channels.

The versatile monitoring system allows the user to pre-select talk and/or listen functions for each channel, giving maximum flexibility in multi-channel monitoring. The operator might choose to preset Channel A for Listen-only, but preselect both Talk and Listen functions for Channel B. System versatility is enhanced by an ALL PAGE momentary over-ride button; pressing this button will cause all preset conditions to be temporarily bypassed, allowing the MS-200 operator to talk to all stations.

A Visual Signal circuit is incorpo-

rated into the MS-200. Pressing the CALL button signals the stations previously selected by the Monitor buttons; for instance, if Channel A is "on," pressing CALL will signal all stations on Channel A only.

When a Remote Station signals the MS-200, the light in the Monitor button assigned to that station will illuminate brightly (regardless of the button's on/off position).

The MS-200 also employs sidetone adjustment controls, which set the overall volume level of your voice as heard in your headset, balance the level per channel, and help to prevent feedback when using an external speaker.

An auxiliary program input on the rear panel accepts balanced or unbalanced line level signals. You may simply monitor this input at the Main Station, or you may mix it with the individual channels. Individual program volume controls adjust overall headset/speaker level and individual channel level.

The mic preamplifier in the MS-200 has a specially designed limiter that maintains a constant level for voice transmittal when speaking volume rises and falls. The regulated power supply delivers 30 volts at 2 amps, and is circuit breaker-protected against shorts in the interconnecting lines. If a short occurs, the front panel circuit breaker will pop out and the adjacent red LED will illuminate.

II. INSTALLATION

A. MAXIMUM AMOUNT OF STATIONS

The MS-200 Main Station supports single or multi-channel Remote Stations. It has a maximum output current capacity of 2 amps; the total current draw on both channels cannot exceed this output. The maximum amount of Remote Stations in a system driven by one MS-200 depends upon four factors:

- 1) the current requirements of each Remote Station
- 2) the length of the wire
- 3) the wire gauge
- 4) the cable capacitance

If your system includes headset stations only, the MS-200 will operate a maximum of 100 units. If your network contains speaker sta-

tions only, the Main Station will support a maximum of 20 units. The majority of applications, however, employ a variety of units.

To determine the total amount of Remote Stations a single MS-200 can support, consult Figure 1. Match the number of speaker/RM-400 stations in your system to the number of headset stations in the system. If the point reached falls within the shaded section of the graph, an MS-200 will drive the entire system with no reduction in performance (on lines longer than 1000 feet, even if they contain only 4 or 5 stations, we recommend adding another power source to provide back-up power if the line is cut).

NOTE: IN ALL CASES, SHIELDED MIC CABLE SHOULD BE USED TO INTERCONNECT THE STATIONS.

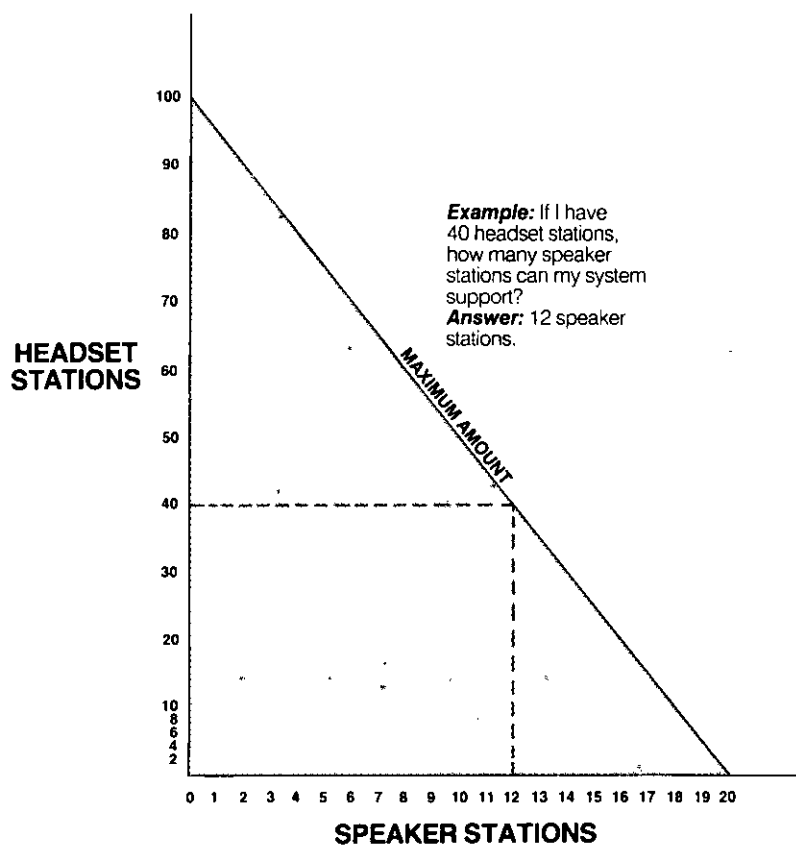

Figure 1: Maximum Amount of Remote Stations

B. CABLE CONSIDERATIONS

The MS-200 Main Station mounts in a standard 19" rack for security and convenience. Cable is run from the rear panel to connect with all remote headset and speaker stations. The rear panel contains three XLR-type, 3-pin male connectors for each channel (six connectors total), and one XLR-type, 3-pin female connector for an auxiliary line input.

Depending upon the application, you will run separate cables for Channels A and B to the single-channel Remote Stations, or Channels A and B will be fed together to dual-channel Remote Stations (crosstalk considerations for the latter set-up are discussed later in this section).

When choosing interconnecting cable, the following considerations are kept in mind:

- 1) DC resistance affects crosstalk. In permanent installations, do not use wire smaller than 20 gauge, stranded (except runs shorter than 100 feet). Keep the total resistance under 100 ohms.
- 2) The capacitance of the interconnecting cable affects the frequency response and sidetone stability. Total capacitance should not be greater than .25 microfarads (capacitance between conductor and shield; equivalent to an intercom network containing 5000 feet of 50 pF per foot of cable).
- 3) Clear-Com Systems operate with cable that has no more than 35 pF from conductor to conductor, and no more than 70 pF from conductor to shield.

PORTABLE INSTALLATION CABLE:

Typical cable for connecting Main Stations or Power Supplies to portable Remote Stations is rubber-jacketed, two-conductor, shielded microphone cable. We suggest you use BELDEN 8413 (24 gauge, stranded) for connections totalling 500 feet and less, and BELDEN 8412 (20 gauge, stranded) for connections that reach up to 5000 feet.*

Portable Remote Stations (designed as belt packs) each have a pair of input and output connectors; when installing a system that includes these, you might "daisy-chain" many stations along one interconnect path. Alternatively, you may use Clear-Com's Quadropuss "splitter" to feed line to stations individually (see Sect. IIF for various hook-up configurations). These methods lessen the amount of cable and simplify installation.

PERMANENT INSTALLATION CABLE:

We recommend you use vinyl-insulated and jacketed cable for connections to fixed installation stations; it costs less and is easier to pull through conduit than the rubber-insulated cable.

Low capacitance cable must be used. We suggest you use BELDEN 8762 (20 gauge, stranded) for applications up to 500 feet, and BELDEN 8760 (18 gauge, stranded) for up to 5000 feet.*

If conduits are available when installing permanent Remote Stations, run interconnecting cables through the conduits to each wall-mounted unit. NOTE: Chassis ground and signal ground (Pin 1) are NOT

the same point. Do NOT connect the chassis and Pin 1 together. The chassis is insulated from the signal ground with a capacitor (.01 microfarad, 1.4kv). This eliminates the hum and potential shock hazards that can arise if stations are at a different ground potential. If the conduits have existing wire, this may be used (whether shielded or not).

In installations where conduit is NOT used, and equipment doesn't share a common ground, it is good engineering practice to run an additional ground wire to tie all chassis together (this decreases susceptibility to electrical noise fields).

*If you choose not to use Belden cable, use an equivalent type with similar wire gauge and capacitance. Cable, especially in longer runs, should have low DC resistance (less than 15 ohms per 1000 feet; large diameter conductors) and low inter-conductor capacitance (less than or equal to 55 pF per foot of cable: capacitance between conductor and shield).

Consult the Belden wire specs (see Figure 2) to ensure that substitute cable is comparable.

Multi-Channel Cable Considerations:

When installing a system that includes permanent two-channel Remote Stations, both Channels A and B may be routed together to each station with two 2-conductor shielded cables OR one multi-pair shielded cable (such as BELDEN 8723).

CROSSTALK

When multiple channels are being fed to Remote Stations, the amount of crosstalk is proportional to the amount of DC resistance in the ground return. Two ohms of resistance or less is ideal; 2 ohms will give you 40 dB of isolation. Anything greater than 2 ohms will increase crosstalk. Each channel must be fed in its own separate shield.

If you're using many wire groups, tie all the ground shields together, achieving the lowest possible resistance. Also tie all the unused wires in the cable to ground, thereby keeping crosstalk down.

Figure 2
Belden Shielded Cables

Trade #	# of Cond.	AWG & (Stranding)	Insulation Thickness (Inch)	Jacket Thickness (Inch)	Nom. O.D. (Inch)	% Shield Coverage	Suggested Working Voltage	Nom. Cap.* (pf/ft.)	Nom. Cap.** (pf/ft.)
8413	2	24 (45x40)	.019	.025	.190	100	300	30	55
8412	2	20 (26x34)	.020	.043	.268	84	600	30	55
8762	2	20 (7x28)	.014	.028	.196	100	350	27	49
8760	2	18 (16x30)	.018	.028	.222	100	450	24	44
8725	8	20 (7x28)	.015	.030	.360	100	400	27	49
8723	4	22 (7x30)	.008	.019	.165	100	400	35	62

* Capacitance between conductors.

** Capacitance between 1 conductor and other conductor connected to shield.

C. INSTALLATION CONSIDERATIONS

Before system installation, consider these pointers to help determine system configuration.

Multiple Power Sources:

Clear-Com Power Supplies and Main Stations are fully compatible. Adding a second power source raises the amount of Remote Stations that may be on the line, and provides back-up security should one source fail. Very long lines should have a power source at each end. NOTE: termination for each channel must take place at one source only. See Section VII.

Complete Loop-Through Set-Up:

A typical intercom configuration (using one channel) might look like this:

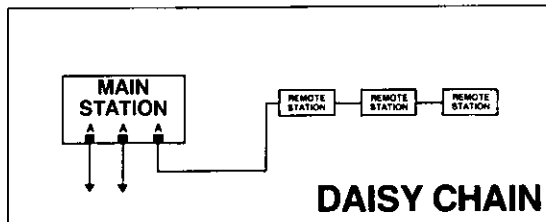

This works well, but if the line were to be cut anywhere along the feed, all stations would go down. An alternative configuration (illustrated below) solves this problem; it makes use of two Channel A connectors on the Main Station's rear panel. Using two connectors to feed one channel line establishes a loop-through that prevents network failure should a cut in the line occur.

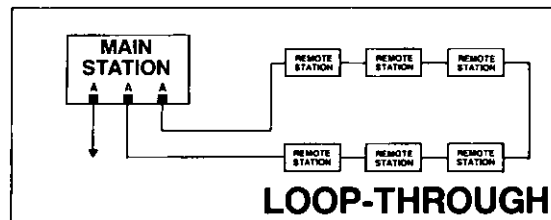

Signalling Configurations In Multi-Channel Systems:

In normal circumstances, the CALL light on a two-channel Remote Station illuminates only when someone signals on the channel that station has previously selected for communication. This is because the Visual Signal travels on the audio line in the form of DC voltage. Alternately, it is possible for you to modify the line feeding any 2-channel Remote Stations (KB-111, CP-100-2CH, MR-102) so that, no matter what channel that group of stations has chosen for communication, their Call lights will go on when either Channel A or Channel B signals.

Consult the block diagram in Section VII (Interfaces & Options) to see how this is done.

In-Line Isolation:

In certain applications you may decide to isolate conversations in one section of the network. Clear-Com offers the Model BA-1 In-Line Isolator, which blocks audio while allowing power to flow to an isolated "leg" of the network. The BA-1 allows one channel to support several simultaneous and independent conversations. The Main Station cannot communicate with the isolated legs of the network. Private local conversations can occur along a common interconnect line without adding great lengths of cable or additional Main Stations. You may incorporate any number of BA-1's, as long as the

power capacity of the MS-200 is not exceeded by added Remote Stations. The following are two approaches to BA-1 incorporation into the network (see Figure 3):

- a. Plug BA-1 into a Remote Station at the end of a cable, therefore using a minimum amount of additional cable to isolate the added and independent Remote Stations.
- b. Plug BA-1 into one output connector on the rear panel of the Main Station, and create an entire isolated channel.

Interfacing with Other Systems:

The Clear-Com Model AC-10K is a universal adapter which enables you to interface a Clear-Com System with any other intercom or communi-

cations link. When an existing non-Clear-Com system is upgraded to Clear-Com equipment, you may retain portions of the older system. The AC-10K "Adapt-a-Com" guarantees compatibility with any in-house intercom equipment, as it is compatible with virtually any 2-, 3-, or 4-wire system.

Because it will simulate a carbon mic, Adapt-a-Com can be plugged into the headset jack of a TV camera, control unit, or other 2-wire system.

Adapt-a-Com operates with telephone company intercoms and other 3wire intercom systems. It facilitates on-line intercommunication via standard telephones, and aids in direct communication between the studio and remote locations via 2- or 4-wire dedicated Telco pairs.

For other interface options (including modification of unit for 230 VAC operation), see Section VII.

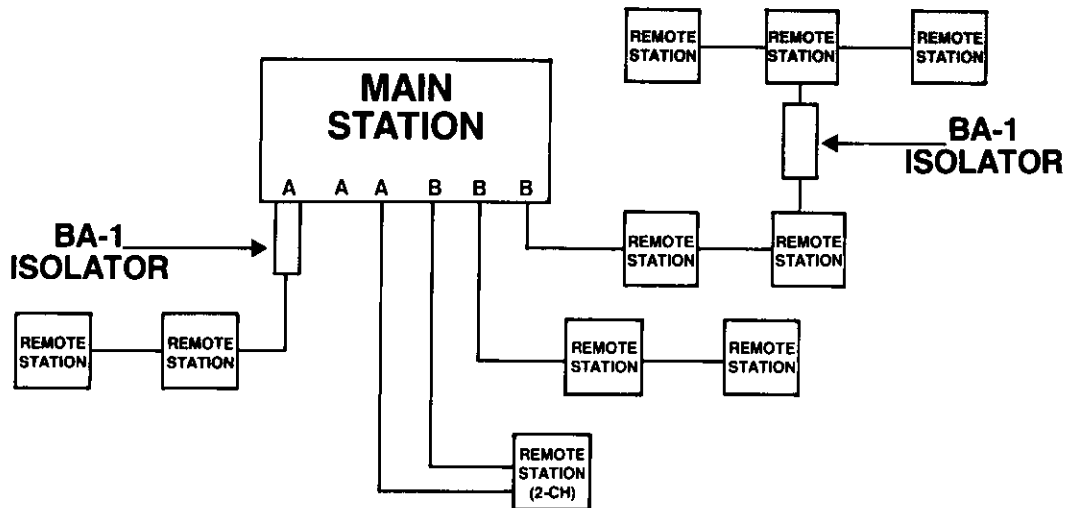

Figure 3
BA-1 ISOLATORS
IN USE

D. INTERCONNECTION SET-UP

Once you determine the configuration of your intercom network, decide upon a location for the Main Station. Then:

- 1) Position the unit near a source of 105-125 VAC (power consumption is 80 watts maximum).
- 2) Use standard 2-conductor shielded mic cable (see previous section).
- 3) Route all cables from the Remote Stations to the Main Station. Direct your cabling in the way most convenient for your configuration. See Figure 4 (2-Channel Installation Wiring). Pin assignments on the six rear panel input connectors (three per channel) are:
 - PIN 1--common
 - PIN 2--+30 volts DC
 - PIN 3--audio
- 4) If there are not enough direct connections on the Main Station:
 - a. individual Remote Stations can be paralleled along a line brought to the rear panel ("daisy-chain" set-up).
 - b. Employ the Model QP-100 "Quadropuss", a three-way line-splitter with one input and three outputs for routing of additional Remote Stations.
- 5) Route cables away from heavy AC power sources, such as lighting panels or electric motors.
- 6) In permanent installations, cables should be installed in accordance with approved local building codes.
- 7) See Section IIF for interconnection set-ups in typical intercom networks.

MS-200 FIXED INSTALLATION WIRING (TWO-CHANNEL)

PROGRAM CONNECTIONS
Pin 1 - GND
Pin 2 } -20dB
Pin 3 } balanced

NOTE:
IF USING
EXT.
SPEAKER,
CONNECT
WITH 1/4"
PHONE
PLUG: TIP
& SLEEVE
TO
SPEAKER.

METHOD I: 4 WIRES, UNSHIELDED IN CONDUIT

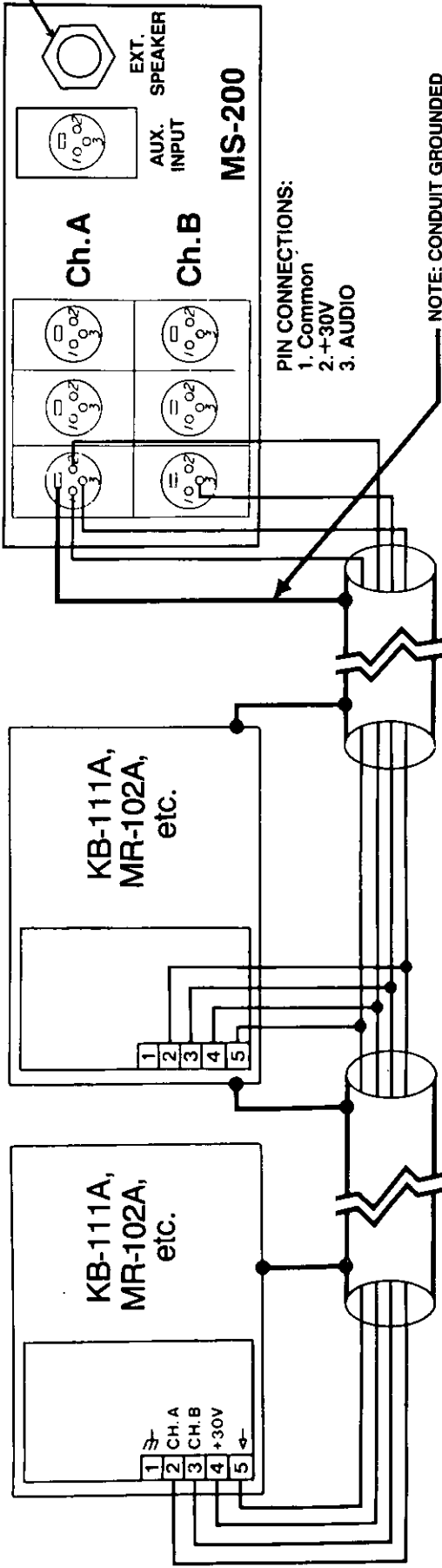

METHOD II: 2 2-COND., SHIELDED PAIR

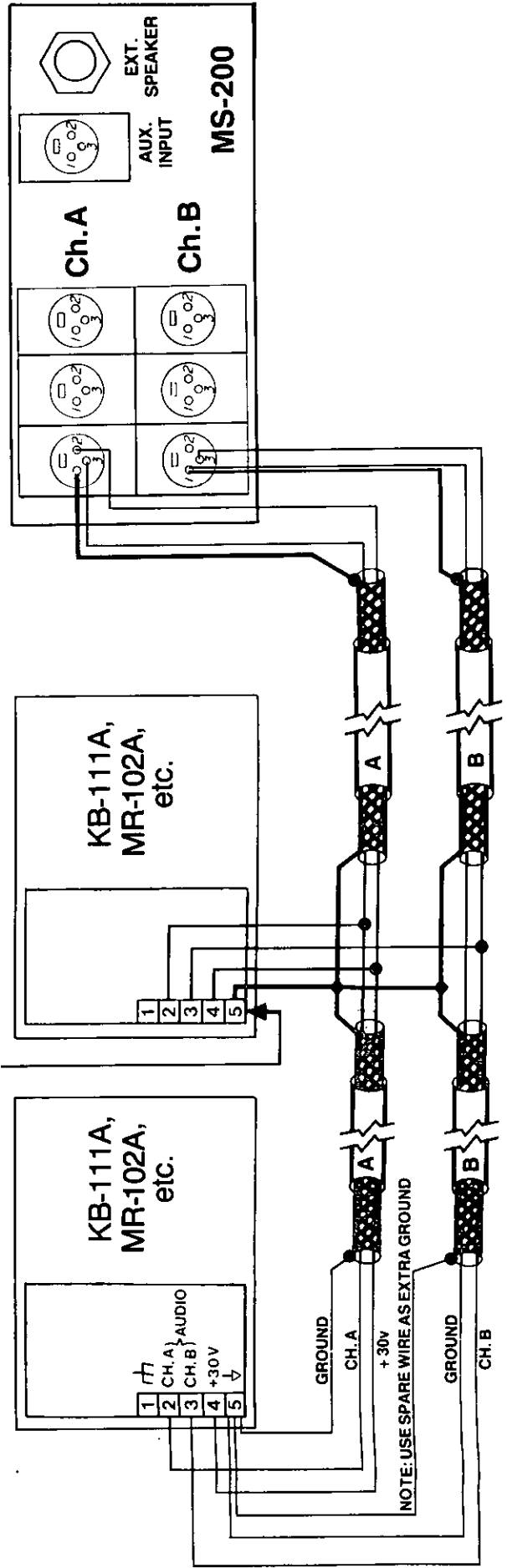

E. HEADSETS AND MICS

All headset connectors in Clear-Com equipment are XLR-type 4-pin male connectors.

To assure proper level and performance, the headsets used with the MS-200 should have the following characteristics:

- 1) Microphone type: dynamic
- 2) Impedance: 150-250 ohms
- 3) Output Level: -55 dB
- 4) Headphone Type: dynamic
- 5) Output Impedance: 8-2000 ohms

Clear-Com offers its users 3 standard headsets, all with boom-mounted, noise-cancelling microphones. Model CC-240B is a double-muff headset, and Model CC-75 B is sin-

gle-muff; both have boom-activated dynamic mics with built-in ON/OFF switches. Model PH-7 is a double-muff, high-fidelity headset with wider frequency response, greater isolation from ambient noise, and a very sturdy physical construction.

The Clear-Com HS-6 telephone-style handset has a dynamic mic and a push-to-talk switch, and is interchangeable with the above headsets. Our Model PT-4 is a hand-held push-to-talk mic for use with speaker stations.

All units have field-replaceable cords.

F. TYPICAL MS-200 INTERCOM SYSTEMS

The following pages describe standard Clear-Com Systems that have been incorporated into a variety of typical settings. On each page is a detailed block diagram of an interconnected system. Unit operators, unit descriptions, and channel assignments are designated.

Since each "typical" locale is

likely to differ, the determination of how and where to run cabling depends upon the lay-out of the area.

These illustrations are intended as general guides to the application of the System. Users' requirements are likely to vary, as will the components of the System.

Key to Clear-Com units and their model numbers:

TWO-CHANNEL SPEAKER STATION
REMOTE WALL MOUNT

(for use with
KB-111A mic/headset)

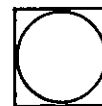

TWO-CHANNEL HEADSET STATION
REMOTE WALL-MOUNT

MR-102A (use with mic/headset)

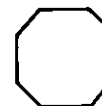

TWO-CHANNEL SPEAKER STATION
REMOTE RACK-MOUNT

RM-120A (for use with mic/headset; optional gooseneck)

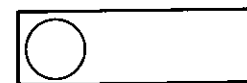

BELT-PACK REMOTE STATION
(For use with headset)

CP-100 (single channel; optional 2-channel)
RS-100A (single channel)
RS-201 (two-channel)



TWO-CHANNEL PORTABLE SPEAKER STATION
KB-111 (for use with mic or headset)
KB-112 (push-to-talk)



WP-2 TWO-CHANNEL WALL PLATE



QP-100 THREE-WAY LINE SPLITTER



AC-10K TWO-WIRE INTERFACE DEVICE

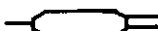

BA-1 IN-LINE ISOLATOR



CC-75B SINGLE-MUFF HEADSET



CC-240B/PH-7 DOUBLE-MUFF HEADSET



PT-4 PUSH-TO-TALK HANDHELD MIC



HS-6 PUSH-TO-TALK HANDSET



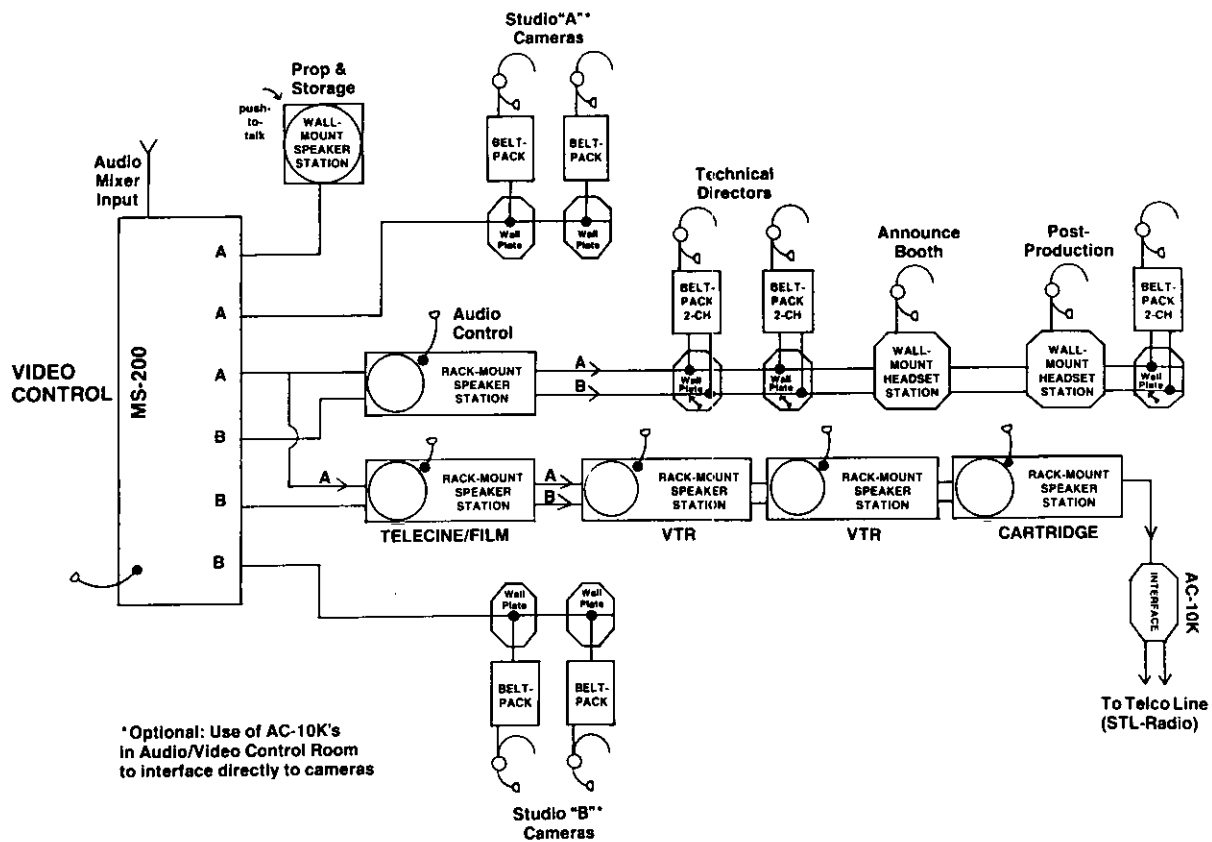

TELEVISION INTERCOM SYSTEM

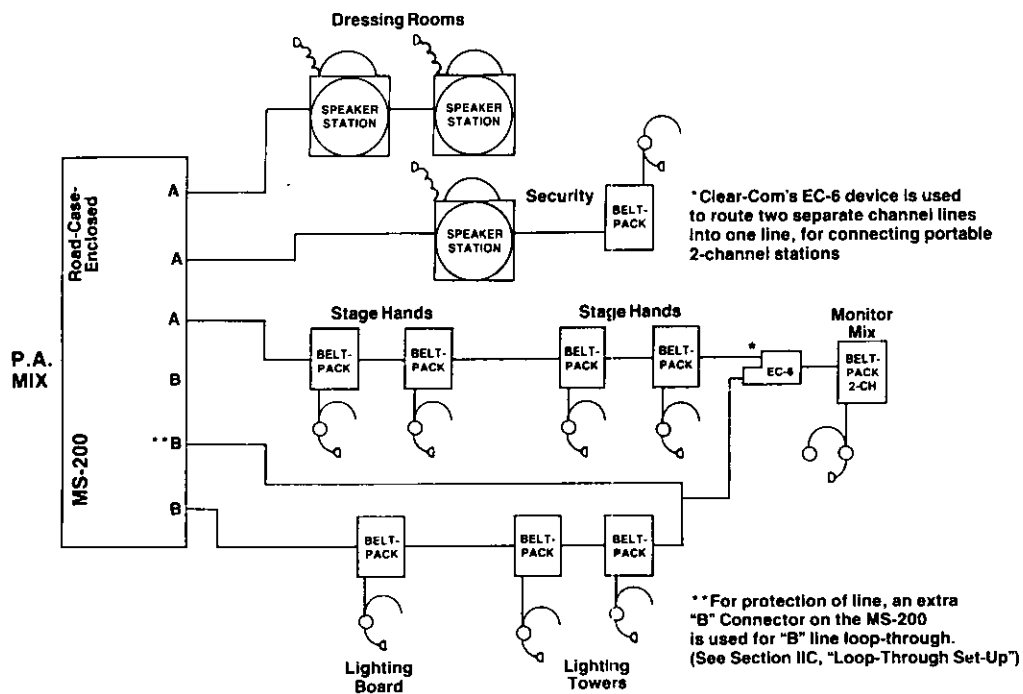

TOURING INTERCOM SYSTEM (Portable)

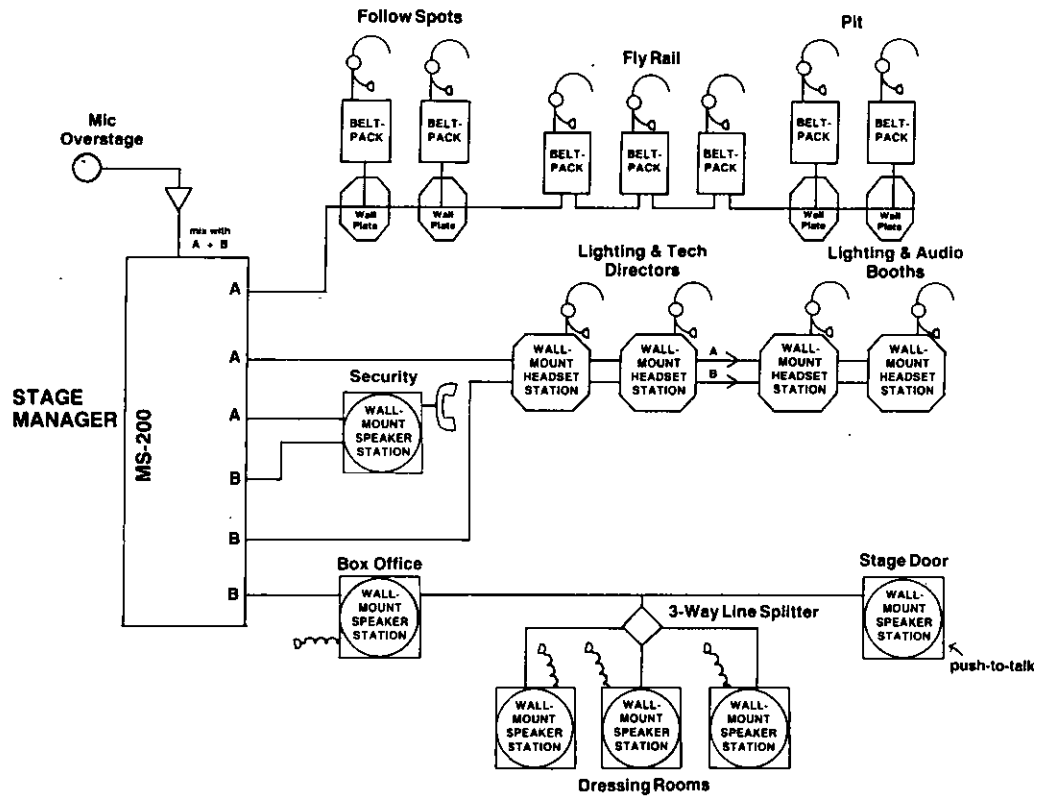

THEATRICAL INTERCOM SYSTEM

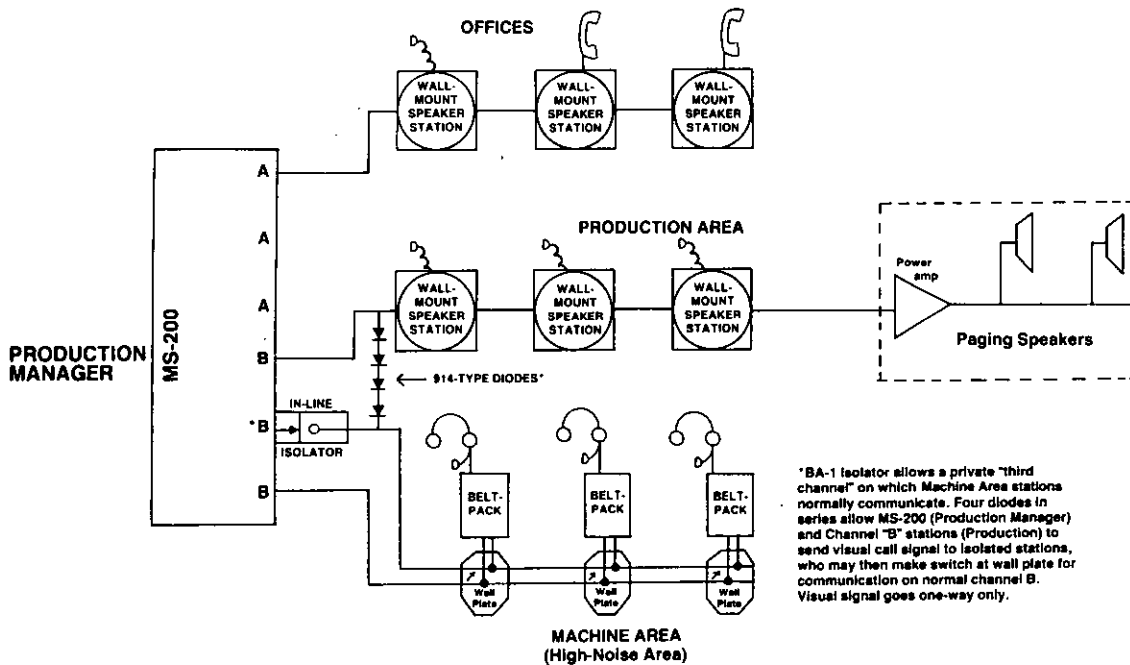

FACTORY INTERCOM SYSTEM

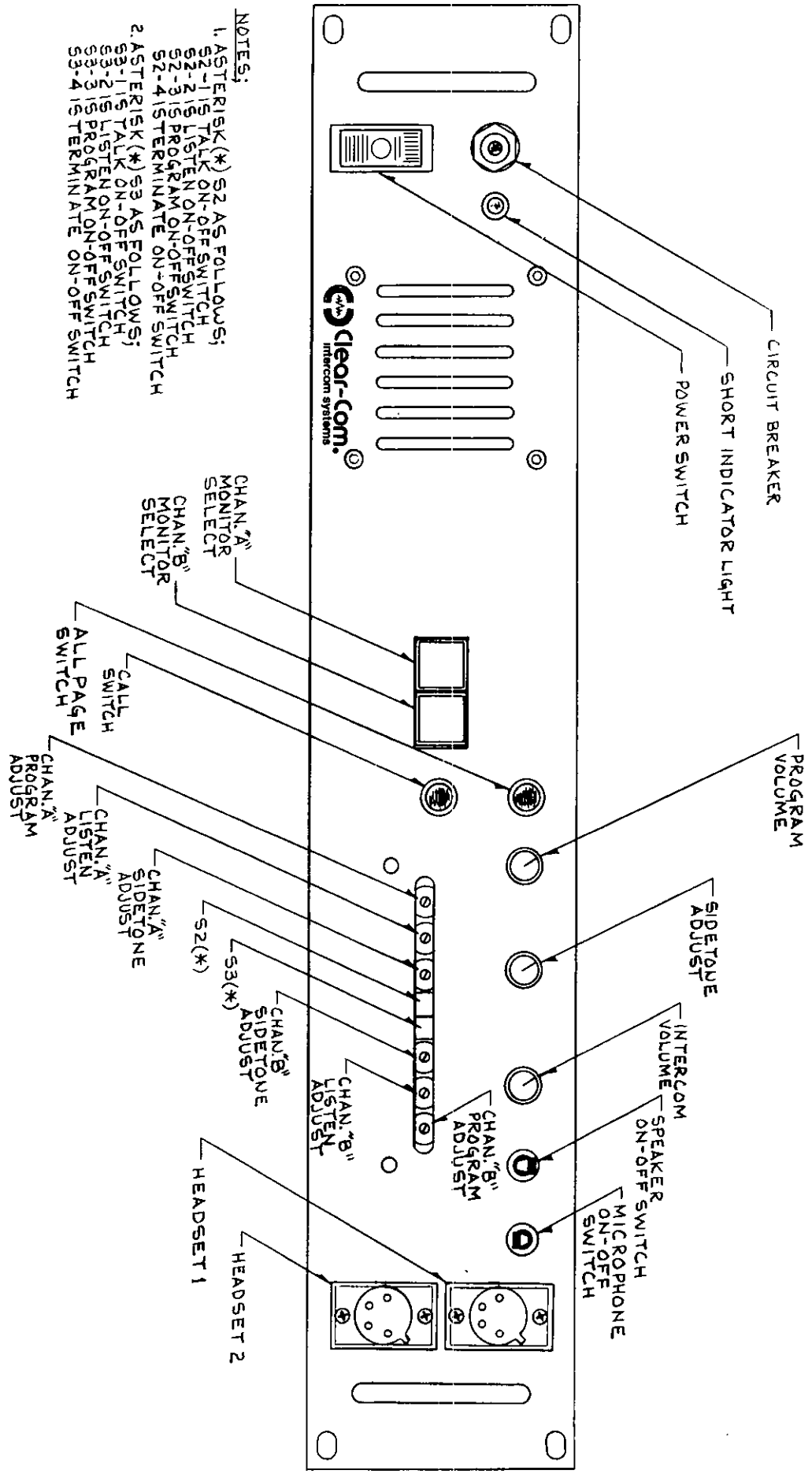

- NOTES:**
1. ASTERISK (*) S2 AS FOLLOWS;
 S2-1 IS TALK ON-OFF SWITCH
 S2-2 IS LISTEN ON-OFF SWITCH
 S2-3 IS PROGRAM ON-OFF SWITCH
 S2-4 IS TERMINATE ON-OFF SWITCH
 2. ASTERISK (*) S3 AS FOLLOWS;
 S3-1 IS TALK ON-OFF SWITCH
 S3-2 IS LISTEN ON-OFF SWITCH
 S3-3 IS PROGRAM ON-OFF SWITCH
 S3-4 IS TERMINATE ON-OFF SWITCH

Figure 5
MS-200 Front Panel

III. OPERATION OF THE MS-200 MAIN STATION

A. Set-Up Procedures

The MS-200 front panel contains a variety of controls, including a recessed set of trimpots and "dip" switches that are located beneath a removable cover plate. A legend is screened onto the unit to identify all controls. See Figure 5, MS-200 Front Panel. For a technical explanation of operation, see Sect.VIII.

Termination:

After completion of cable routing and unit interconnection, system termination must be considered. Only one termination per channel is needed, which may be accomplished at the MS-200.

Both termination dip switches (beneath the cover plate) must be "on," even if one of the channels is not in use.

If your network includes another MS-200, an MS-400, or any RM-400 Remote Station, its termination switches should be "off" while the MS-200 is terminating the system. If, however, the MS-200 doesn't feed to all channels of the other multi-channel station, then the latter's termination switches for the unused channels must be "on." If the MS-200 feeds only one channel to a dual-channel Remote Station, the Remote Station operator must maintain communication on the channel being fed; if he switches from Channel A to the unused Channel B, his station will experience oscillation.

Headsets, External Speaker, and Gooseneck Mic:

There are two headset connectors on the front panel of the MS-200; one has a switched mic, and the other is unswitched. The switched connector has the mic ON/OFF toggle

switch next to it.

When the headset jack is unused, the gain of the amplifier is reduced from 50 dB to unity gain, eliminating pick-up from the unused input.

The headset connector pin-out assignment is:

PIN 1--mic common
PIN 2--mic hot
PIN 3--headphone common
PIN 4--headphone hot

When operating the unit, do not situate the headset(s) near any AC device, or a hum will be induced into the system.

The MS-200 speaker is controlled by the speaker ON/OFF toggle switch on the front panel. The intercom volume knob adjusts the level of the speaker as well as the level of the headset.

If you decide to use an external speaker, do not use one with less than 8 ohms impedance. Connect its two wires to the tip and sleeve of a 1/4" phone plug; then plug into the external speaker jack located on the MS-200 rear panel.

The external speaker is also controlled by the speaker ON/OFF toggle switch on the front panel. Use of an external speaker disconnects the built-in speaker.

If you have a permanently-installed gooseneck mic, the original front panel mic ON/OFF toggle switch is replaced by a momentary ON pushbutton. To activate the gooseneck, depress this button and hold it while talking. To help reduce feedback when the mic button is activated, a dipper circuit attenuates the speaker output by approximately 10 dB. To get maximum speaker output without feedback, turn the front panel side-tone knob fully counter-clockwise.

Program Input:

The auxiliary program input jack is located on the MS-200 rear panel. The program input uses a differential amplifier to accept a balanced or unbalanced program signal without using a transformer. A -25 dB signal will drive the line to full output. The input impedance of the program amplifier is approximately 50K ohms.

Initially, the program is sent to the headset and external speaker jack of the MS-200. The front panel Program Volume knob adjusts the audio level of program reaching the headset/speaker.

You may also mix program with Channel A, Channel B, or both. With this method, the program and intercom signal are mixed at the MS-200 and the combined signal is sent to all Remote Stations.

Beneath the front panel cover plate are the dip switches associated with program. If one (or both) of the channels is to receive program, switch the appropriate program dip switch to the "on" position (if the program is not to be sent down the intercom channels, the program dip switches should both be set at "off").

The volume of program mixing with each individual channel is set by adjusting the appropriate two trim-pots (labelled "program") beneath the cover plate.

Preselection of Channel Activity:

Four dip switches beneath the cover plate (two per channel) are manipulated prior to operation to determine specific channel functions.

At the factory, Clear-Com sets the dip switches for Talk and Listen activity on both Channel A and Channel B. You may decide to change the functions of either channel to Talk only or Listen only. If so, adjust the appropriate Talk and Listen dip switches.

Use a grease pencil in the space provided on the cover plate to notate each Channel's function or to identify stations on each channel (i.e., Channel A: Dressing Rooms; Channel B: Lighting Crew).

Monitor Select Buttons:

The functions of each channel are set by dip switches, while communication activity for each channel is activated by two locking pushbuttons called "Monitor Select."

Depressing the Monitor button for Channel A or B enables that channel for communication; the locked button will light dimly. The operator can monitor each channel separately or simultaneously.

The appropriate Monitor Select button will light brightly if a Remote Station on that channel calls the Main Station; a Monitor button will light brightly when signalled regardless of its on/off position. Both Monitor Select buttons might be "off" simultaneously if your network includes an additional Power Supply or Main Station to provide the voltage/audio line for each channel.

Call:

Pressing CALL activates the Visual Signal circuitry in the system, allowing the Main Station operator to attract the attention of operators away from their Remote Stations.

The CALL button will signal the stations assigned to the channel previously enabled by the Monitor Select buttons. If Channel A is "on," pressing CALL will signal only those stations on Channel A. If both channels are enabled, all connected stations will receive the call signal.

All Page:

This button is pressed if the Main Station operator wants to make an announcement to stations on both channels; ALL PAGE allows one-way communication (talk only) from the MS-200 to all Remote Stations, overriding the positions of the Monitor Select buttons and dip switches.

Variable Controls:

PROGRAM VOLUME (1)

INTERCOM VOLUME (1)

LISTEN TRIMPOTS (2)

Use the two front panel Volume knobs to adjust the audio level heard in the Main Station's headset/speaker.

Adjust the two recessed trimpots to balance the audio levels of the two channels as heard in the Main Sta-

tion's headset/speaker.

SIDETONE ADJUST (1)

SIDETONE TRIMPOTS (2)

Use the front panel Sidetone knob to adjust the volume level of the Main Station operator's voice as heard in the Main Station headset. It simultaneously prevents feedback when using an external speaker.

Adjust the sidetone trimpots (one for each channel) for maximum null, one channel at a time.

POWER SHORT BUTTON

LED SHORT INDICATOR

Next to the circuit breaker "reset" button is an LED that illuminates when the breaker pops, visually confirming the existence of a short circuit or phase reversal in cabling. After removing the short in the interconnect cable, press the button to reset the system.

B. Operational Checklist

Prior to Operation:

- 1) Determine which stations are to be Channel A and which will be Channel B; interconnecting cable is plugged into appropriate A/B connectors (XLR male) on rear panel. If program is to be included, use rear panel auxiliary input (XLR female).
- 2) Connect power cord to a source of 105-125 VAC, 50-60 Hz, and turn power switch to "on" (which will illuminate switch).
- 3) Set termination dip switches for each channel.
- 4) Determine activity and functions of each channel and set appropriate dip switches (Program, Talk, Listen).
- 5) Turn on MS-200 speaker and/or headset mic with appropriate toggle switch.
- 6) Enable MS-200 communication with each channel with Monitor Select buttons (an enabled switch will light dimly).
- 7) Test communications with stations on each channel so you can adjust the following controls for MS-200 headset/speaker volume levels:
 - Sidetone trimpots (one per channel, set for max null)
 - Listen trimpots (one per channel)
 - Sidetone Adjust (knob)
 - Intercom Volume (knob)
- 8) If applicable, adjust Program Volume knob; also adjust appropriate Program trimpots to set program levels for the individual channels selected.
- 9) Test Call button for each channel.
- 10) Test All Page to ensure it overrides all settings.

C. Warranty and Maintenance

Your Clear-Com System contains modular, solid-state equipment that allows system expansion and field servicability. All units are fully compatible.

Clear-Com's rugged packaging guards against abuse; the units are housed in 16-gauge aluminum or stainless steel, and contain double-sided, glass epoxy, plug-in PC boards. Efficient ventilation is inherent in the chassis design. Our conservatively engineered circuitry assures the longest component life. We shield heavily against hum, RF pick-up, and solid-state dimmer (SCR) noise.

Before shipping, we test each unit individually to ensure that it meets or exceeds all specifications. All units are guaranteed by Clear-Com against defects in materials and workmanship for one year (90 days for headsets) following date of purchase (see your warranty card for details).

Our Engineering Department will gladly give technical advice and assistance. If you have any questions regarding operation, modifications, or applications of Clear-Com, call us during business hours at 415-861-6666 (Pacific Standard Time).

IV. TROUBLESHOOTING

<u>Symptom</u>	<u>Cause</u>	<u>Remedy</u>
System is non-operable; power switch is not illuminated	<ul style="list-style-type: none"> a. Loss of AC power b. Internal fuse is blown; could be caused by power supply failure. 	<ul style="list-style-type: none"> a. Plug unit into dependable AC source b. Replace fuse; if it blows repeatedly, bridge rectifier or other component probably shorted inside power supply. Have power supply fixed.
Circuit breaker trips repeatedly; short circuit LED remains lit	<ul style="list-style-type: none"> a. Shorted or mis-wired interconnect cable b. Defective remote unit 	<ul style="list-style-type: none"> a. Remove cables, one at a time, from Main Station until faulty line is located. Check for shorts between Pins 1 and 2. b. Check remote unit.
Hum or buzz in system	<ul style="list-style-type: none"> a. Inductive pick-up caused by close proximity of Main or Remote Station to power lines or transformers. b. Due to ground loop, caused by improper grounding of system. c. 10 ohm chassis ground resistor (R14) in power supply is open* d. inductive pick-up by headset mic; check by switching mic on and off 	<ul style="list-style-type: none"> a. Relocate offending unit. b. Reverse power cord, lift ground (see Installation Instructions). c. Check resistance between chassis and Pin 1 of connector, make sure it's ten ohms. If not, open power supply and replace resistor. d. Move mic away from "hum field" or use carbon or electret headset.
Excessive background noise pick-up by mic	<ul style="list-style-type: none"> a. distance from mic to lips is too far b. volume too high c. too many mics "on" in entire system 	<ul style="list-style-type: none"> a. Move closer to mic b. Lower headset/speaker volume c. Turn off all unused mics

(continued)

<u>Symptom</u>	<u>Cause</u>	<u>Remedy</u>
System Feedback	Acoustical	a. Check sidetone levels b. Check termination c. Volume too high at one station d. Two or more speaker stations have mics on simultaneously; speak one at a time (per channel)

* Power Supply's 10-ohm resistor is opened when the system ground comes in contact with something "hot," with respect to the Main Station Earth Ground. Should this occur, we recommend you carefully check the system ground and AC distribution in the area. **NOTE: THIS IS A POTENTIALLY DANGEROUS SITUATION; IF IT OCCURS, A SHOCK HAZARD MAY OCCUR BETWEEN GROUND AND THE METAL BOOM OF A HEADSET.**

V. SPECIFICATIONS

AMPLIFIER DESIGN:

IC amplifiers including solid-state switching and signalling circuits. Current limited and short-circuit protected.

MICROPHONE PRE-AMP:

Microphone Input: 200 ohm nominal dynamic type
Mic Input Level: -55 dB nominal
Frequency Response: 250 Hz-12kHz with a contoured response to enhance voice intelligibility.
Gain Adjust: ± 5 dB
Limiter Range: 15 dB

HEADPHONE AMPLIFIER:

Output Impedance Range: 8-2000 ohms
Output Level-
Speaker: 4 watts into 8 ohms
Headset: +20 dBm into 600 ohms
Distortion: <0.5% THD 1kHz
Amplifier Gain: 35 dB
Frequency Response: 150-18k Hz ± 2 dB

PROGRAM AMPLIFIER:

Switchable, 0-2 channels; individual gain controls.
Frequency Response: 150-18k Hz
Input: 47k ohms transformer-less balanced
Input Level: >15 dB nominal; +2 dB max
Common Mode Rejection: >50 dB

POWER SUPPLY:

Output voltage: 30 volts regulated; circuit-breaker protected.
Output current: 2 amps maximum

VOLTAGE GAIN:

Mic-to-Line: 35 dB nominal
Mic Gain Adjust: ± 5 dB
Line-to-Output: 35 dB

CHANNEL SEPARATION: ≥ 50 dB

SIGNAL TO NOISE: >55 dB

SIDE TONE: Adjustable from >25 dB null to full on

OPERATING CONDITIONS:

Channel Monitoring:

Programmable Channels A and B with illuminated push on/off switches.

Call Light Monitoring:

Follows channel select switch.

Capacity:

Will support up to 100 headset remote stations or 20 speaker remote stations.

System Impedance:

200 ohms or 15k ohms bridging, switchable.

System Level:

-15 dB nominal; 0 db before clipping.

Signalling:

Call Light Sensitivity--4 vdc
Signalling Voltage--11 vdc

CONNECTORS:

Headset Inputs: (2) D4M
Outputs: (6) D3M
Auxiliary Input: (1) D3F
External Speaker Jack disconnects internal speaker.

AC POWER REQUIREMENTS:

105-130 VAC; 48-62 Hz; 80 watts maximum. May be modified for 210 to 260 VAC.

DIMENSIONS:

19" wide, 3.5" high, 9" deep

AMBIENT TEMPERATURE TOLERANCE:

0-50 degrees C (32-122 degrees F)

VI. MS-200 PARTS LISTING

<u>PART #</u>	<u>DESCRIPTION</u>	<u>QTY.</u>	<u>LOCATION/REF. DES</u>
710044	Power Supply Module*	1	Internal
710114	Mother Board Module*	1	Internal
210013	Headset Connector, D4M	2	Front Panel ("FP")/J1, J2
510006	Switch, toggle, 2-pos.	2	FP/S1, S8
240015	Knob, blk, 1/2", 1/8" shaft	3	FP/P10, P12
510028	Switch, momentary push 240020 (Red cover button) 280067 (Dress cone nut)	2	FP/S6, S9
510035	Switch, 2-gang illum. push 390005 (Lamp, 24v, #327)	1	FP-Internal/S4, S5
250124	MS-200 Cover Plate, black	1	FP
500089	Speaker, 3" round, 8 ohm	1	FP
390007	LED, red	1	FP/I1
520019	Circuit Breaker Assy.	1	FP-Internal/CB1
510002	Switch, rocker, red illum.	1	FP/S7
240007	Handle, 2"	2	FP
210002	Pgm Input Connector, D3F	1	Rear Panel ("RP")/J9
210003	Intercom Connector, D3M	6	RP/J3-J8
210055	External Speaker Jack	1	RP
560001	Power Transformer	1	RP-Internal/T1
610000	Power Cord set	1	RP-Internal
180000	Filter Choke, 15MH	1	RP-Internal/L1

* Refer to Schematics for components on circuit boards.

VII. INTERFACES & OPTIONS

The following diagrams illustrate how you may interface your Clear-Com network with various other systems (2-wire, 4-wire, and wireless). Figure (b) shows use of the Adapt-A-Com to connect Clear-Com with other 2 or 4 wire systems; Adapt-A-Com can also be used to communicate over long distances. Figure (c) shows a two-wire unbalanced pair used in another method to communicate on Clear-Com over long distances.

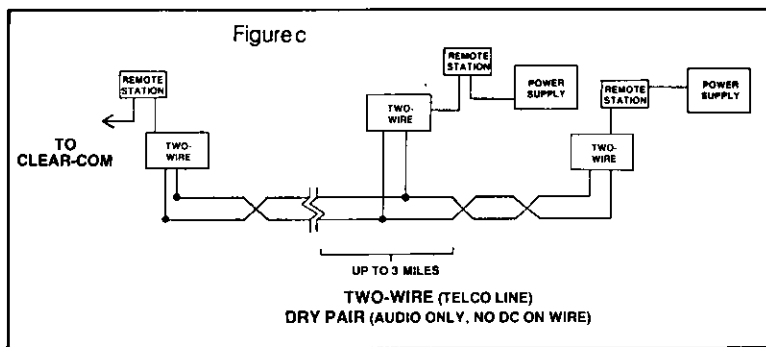
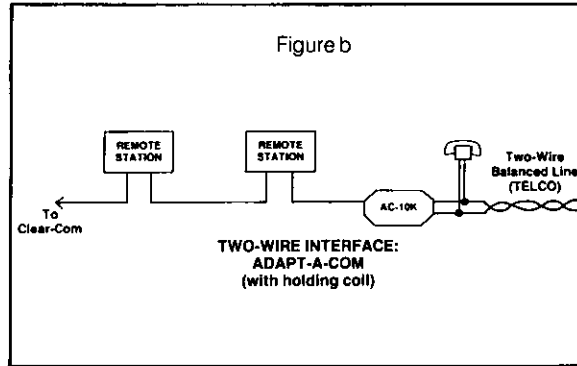
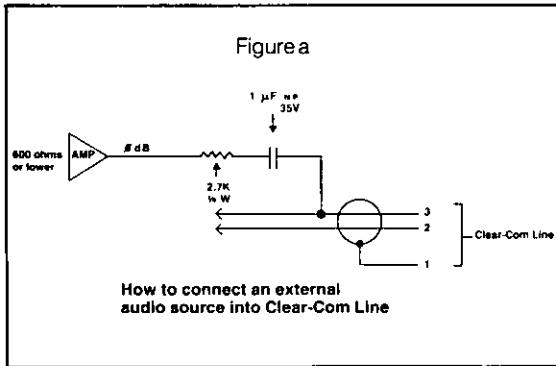

To interface with a wireless system or a 4-wire device such as a TV camera, without adding an interface unit:

- 1) Use any Clear-Com Remote Station (i.e., RS-100A) as the interface
- 2) Accomplish interfacing through the Station's headset connector with the adapter ("Attenuator Pad") that is shown below:

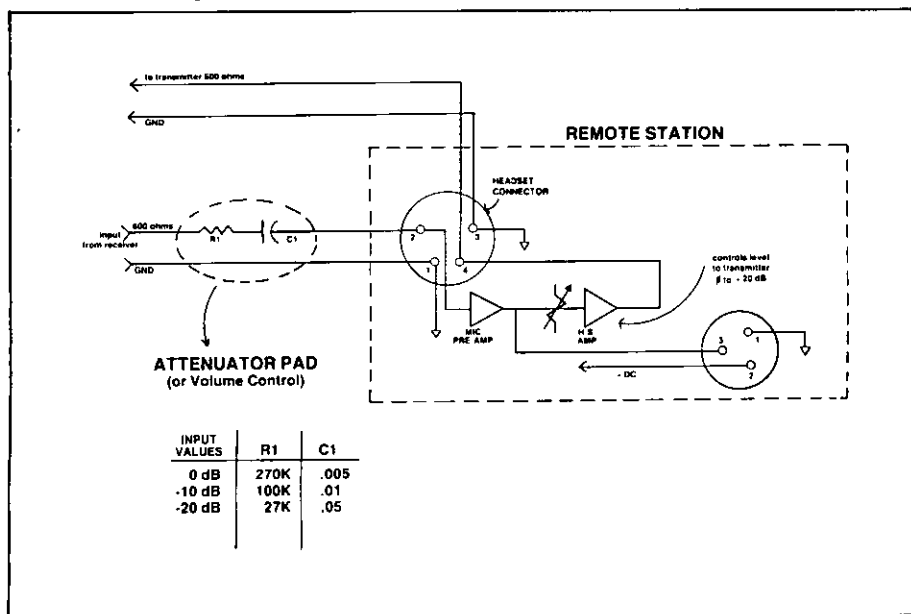

Visual Signalling Modification

Each two-channel remote stations normally communicates on Channel A or B. Likewise, each two-channel station can send or receive the visual call signal on its assigned channel only--unless the following modification is made.

In our application, a group of two-channel stations talking on Channel B want to receive visual call signals from stations on Channel A (this is one-way signalling; Channel B cannot send a signal to Channel A).

This is achieved by placing four diodes (914-type) in series on the two-channel intercom line as shown below. The visual call signal follows the direction of the diodes. Call signalling is now possible from "A" stations to "B" stations.

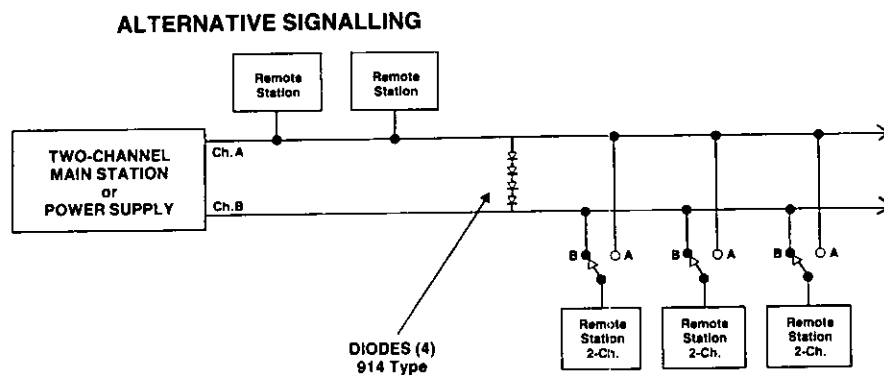

Main Station/Power Supply Interconnection

Adding an extra Power Supply to the intercom line increases the maximum Remote Station capacity of the System by increasing its output current capability. Another Power Supply also provides back-up security should the other power source experience failure. The following diagram illustrates the interconnection between units, which may be at the same end of the line or at each end. Note that termination for each channel should take place at only one Power Supply or Main Station. (Termination slideswitches in the PS-452 Two-Channel Power Supply are located atop the circuit board behind the front panel.)

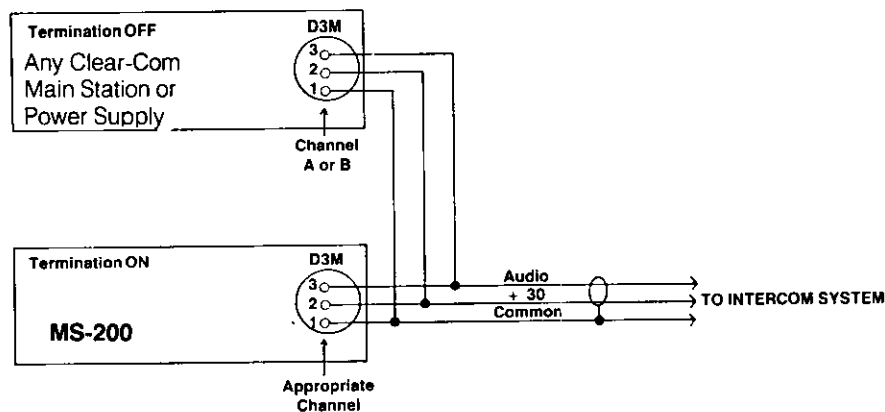

Conversion to 220 VAC Operation

Unless ordered otherwise, the MS-200 Main Station is factory-wired for 110 VAC operation. To modify it for use with 220 VAC power systems, take the following steps:

- 1) Turn off unit, disconnect power cord, and remove top cover
- 2) The Power Transformer and its associated wiring are located at the left rear of the chassis (where the power cord enters). Locate the white, crimped, cap-style connector (squid cap) that connects the BROWN and WHITE wires from the Power Transformer to the WHITE/BROWN wire from the power switch middle terminal.
Remove the squid cap by cutting it off where the wires enter the body of the connector.
- 3) Locate and remove the squid cap connecting the BLACK and BLACK/WHITE transformer leads to the WHITE lead from the power cord and the WHITE wire from the power switch bottom terminal.
- 4) Untwist the BROWN, WHITE, BLACK, and WHITE/BLACK transformer leads. Strip approximately 3/8" of the insulation from each lead.
- 5) Strip approximately 3/8" of the insulation from the WHITE and WHITE/BROWN wires from the power switch.
- 6) Re-twist the WHITE and WHITE/BLACK transformer leads and connect the pair to the WHITE wire from the power switch bottom terminal using a squid cap, wire nut, or solder.
- 7) Connect the BROWN transformer lead to the WHITE/BROWN wire from the power switch middle terminal.
- 8) Connect the BLACK transformer lead to the WHITE lead from the power cord.
- 9) Remove the 1 amp, slow-blow fuse on the power supply regulator PC board.
- 10) Replace with .5 (1/2) amp, slow-blow fuse (Buss MDL 1/2, Littlefuse 313.500 or equivalent).
- 11) If necessary, cut off and replace the power cord plug to fit power system needs.
- 12) To prevent shock or fire hazard, insulate all connections with heat-shrinkable tubing, plastic electrical tape, or other suitable electrical insulation.

VIII. THEORY OF MS-200 OPERATION

The following is a technical description of the operating circuits within the Model MS-200 Main Station. Consult the two schematic diagrams to determine location of specific components within the circuits.

The MS-200 Two-Channel Main Station consists of five distinct parts:

- (1) switching circuitry
- (2) pre-settable monitor circuitry (including side tone)
- (3) program circuitry
- (4) signalling circuitry
- (5) regulated power supply

SWITCHING CIRCUITRY:

Switching the intercom lines is accomplished by switching the talk and listen circuits in and out of the system. This is done with DC control of analog switches IC3 and IC5.

MONITOR CIRCUITRY:

The Monitor Circuitry consists of a low-level, adjustable mic preamp (IC1), limiter (Q1), line drivers, high-impedance bridging circuits (IC4, IC6), summing amp (IC7), and a 4-watt power amp (IC8).

A mic level signal is applied to the preamp where it is amplified approximately 50 dB. Two internal trim-pots allow gain adjustment of each mic input by +/- 10 dB. These controls are set at the factory to give a standard level on the line, so all Clear-Com products will match. The mic limiter is set so the voice level is kept constant over a 20 dB range. From there the signal goes through the analog switches (IC5 and IC3), to the line drivers and to the individual intercom lines. The line buffers raise impedance to approximately 15k. The signal level on the line is approximately -15 dB.

The receive signal from the line (after going through the line buffer and individual level trim controls) is combined into a buffer amplifier for both channels. The output of the buffer amp is fed into the power amp through a master volume control. The output of that goes to the headset and the speaker.

The side tone circuit works by taking a portion of the signal from the mic preamp output and mixing it in with the listen signal. There are three sidetone adjustments; two of them are between the line-driver and line-buffer of each channel. Here, sidetone is adjusted for maximum null. The third adjustment (made through front panel trim pots) mixes some of the signal of the mic preamp back into the headset, allowing you to set the level of your voice as heard in the station speaker or headset from full on to a 35 dB null. This does not affect any signal sent to the intercom line.

SIGNALLING CIRCUIT:

The visual signalling circuit consists of two signalling circuits. When the call button is depressed, Q3 and Q4 are activated (depending upon which Monitor Select button is "on"). The output of Q3 and Q4 applies a DC voltage of approximately 11V onto the audio line, and activates the appropriate call light switch (Q5 or Q6), illuminating the CALL light(s).

If signalling comes into the MS-200 on Channel A or B, the DC voltage is also applied to Q5 or Q6, brightly illuminating the Call light in the appropriate Monitor Select switch. The call-receive circuit requires only 4 volts (at 100 microamps) to turn on the

light. The 7-volt difference between the call-send and call-receive voltages assures positive signalling even when using very long lines.

PROGRAM:

The Program signal is applied to the differential program amp and the program buffer (IC2). The output of the program buffer splits into two paths: one path goes through the front panel program volume control and gets mixed in with the intercom signal before passing the headset volume control. This path applies only to the headset (and speaker) of the main station, and does not get out to the line.

The other path is applied through separate program level trim controls P1 and P6, through the analog switches, and then mixed with the intercom signal (IC6 and IC4) and sent to the line. The intercom channel that is to receive program is selected with the program dip switch, which activates the appropriate analog switch, IC3 or IC5.

POWER SUPPLY:

The power supply mains voltage comes in to the bridge rectifier, through the choke-filtering circuit consisting of L1, C1 and C2, and through the regulator, Q1. Resistors R8 and 9 form a voltage divider along with transistor Q4, which sets the reference voltage to 30V. Transistor Q2 current-limits the supply to protect it from shorts. The design of this power supply is such that it will regulate line-and-load to one ampere, and then regulate line only above 1 amp. This allows the supply to operate continually, even with partial shorts and heavy loads, without completely shutting off. A circuit-breaker on the supply's output will hold till 2 amps.

Over-voltage protection is provided by SCR-1, which crowbars the output of the Power Supply if the regulated output voltage exceeds 35v.

Diode D5 protects the Station's power supply from reverse current, so any additional Power Supplies may be included in the system.

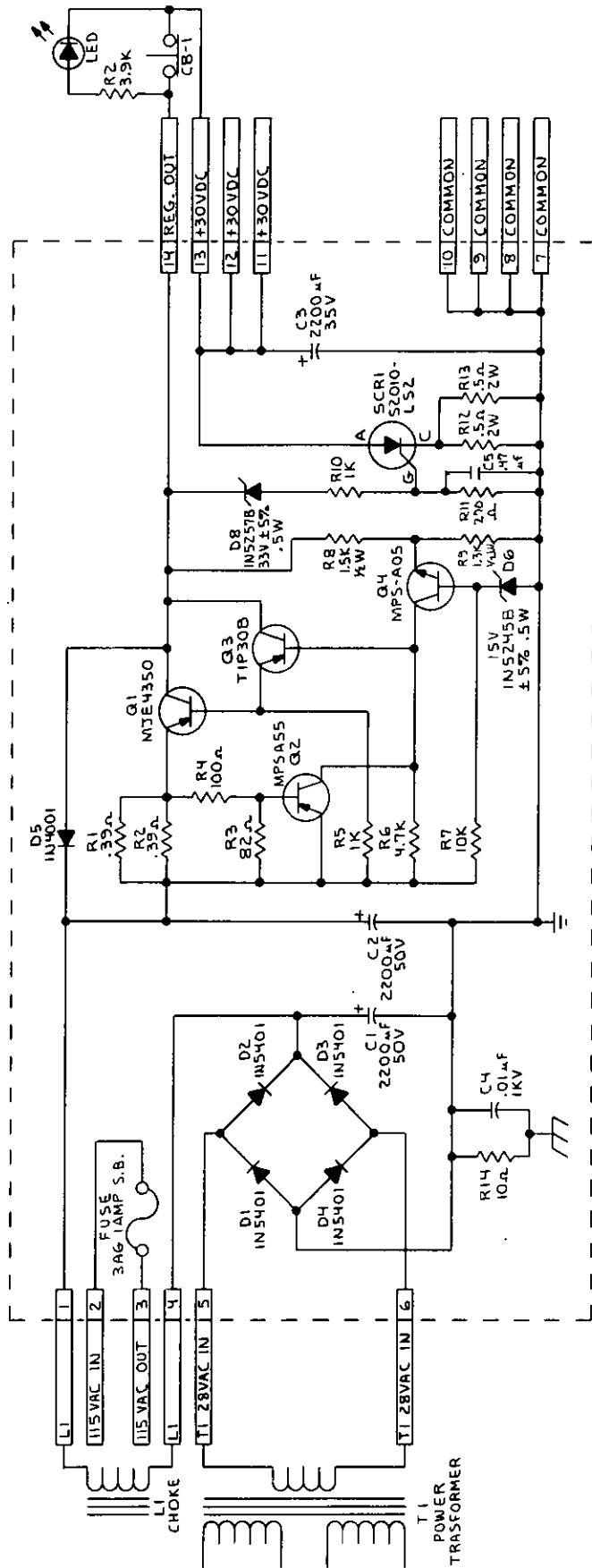

NOTES:
 1. PARTS INSIDE DOTTED LINE ARE MOUNTED ON PCB.
 2. FOR 230V OPERATION USE 1/4 AMP SLOW BLOW FUSE.

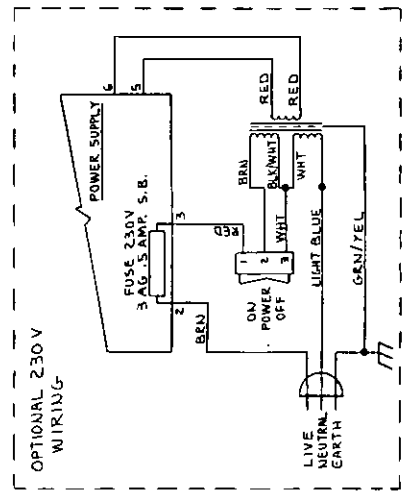

Clear-Com. intercom systems	
SCHEMATIC 1/2 REG. POWER SUPPLY	
SCALE	SEE DRAWING NO.
NONE	C 7144-SCD-C-C
DO NOT SCALE DRAWING SHEET 1 OF 1	

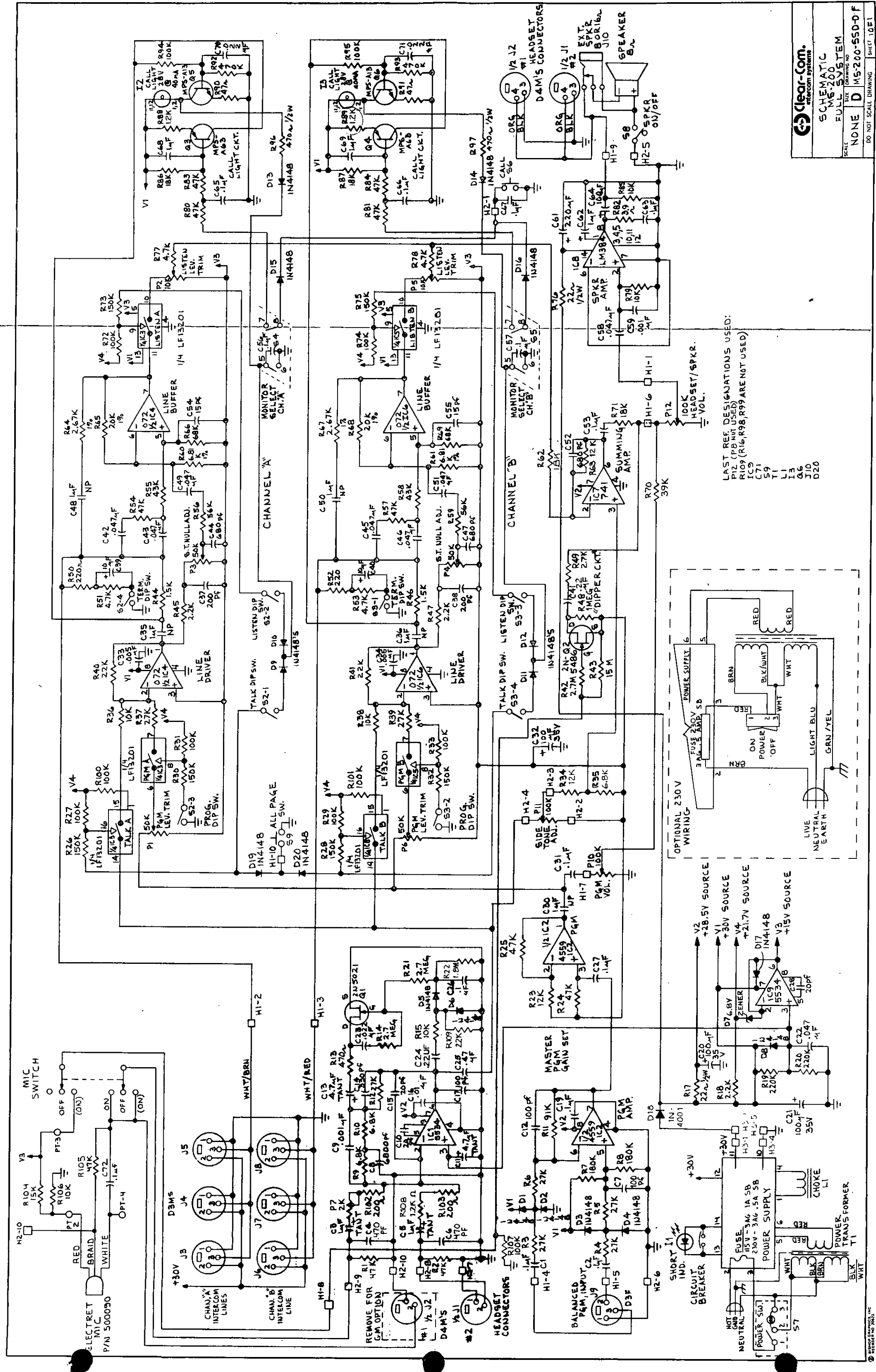

LAST REF. DESIGNATIONS USED:
 P12 (PD NOT USED)
 R109 (R16, R98, R99 ARE NOT USED)
 IC9
 C71
 S9
 T1
 L1
 G6
 J10
 D20

Clear-Com. intercom systems	
SCHEMATIC MS-200 FULL SYSTEM	
SCALE	NONE
DRAWING NO.	D
MODEL	MS-200-SSD-DF
DO NOT SCALE DRAWING	
SHEET 1 OF 1	